

IEEE PES conference on Innovative Smart Grid Technologies

Jan 21st 2010

Prafulla Deo & Tushar Shah

***Innovative Electromagnetic Dynamic
Fault current Limiter operating at
Ambient Temperature for
Smart Grid***

Innovative Electromagnetic Dynamic fault current Limiter
Prafulla Deo & Tushar Shah

Relevance of Fault current limiters to Smart Grid



An important feature of the smart grid is stability and reliability achieved through inherent responses of components and supervisory controls.

Short circuits are major destabilizers for the grid both in magnitude and transient effects. They can lead to progressive and permanent damage to network components as also cascading failures including blackouts.

Fault current limiters (FCL) prevent high short circuit currents thus reducing the electromagnetic and thermal stresses while limiting network disturbances.

Dynamic FCL (DFCL) presented here is an inherently smart device as it responds to the varying fault or source impedances to keep the short circuit current limited to safe values and still prevent fault hanging.

Hazards due to High short circuit currents –



- *Excessive electromagnetic stresses - $F_{max} \propto I_{peak}^2$*
- *High thermal stress due to quick temperature rise – $I_{sc}^2 * t$*
- *High voltage drop in the network - $VD = I_{sc} * Z_{source}$*
- *Large arc energy in the fault leads to fire hazards – $E = I_{sc}^2 * r * t$*
- *Large arc energy on the fault clearing switchgear – $E = \frac{1}{2} L * I_{sc}^2$*
- *Cascade tripping and Black outs*

*Limiting the short circuit current is very
Important for smart grid*

Innovative Electromagnetic Dynamic fault current Limiter

Prafulla Deo & Tushar Shah

Some of the fuse-less Fault current Limiter Technologies -

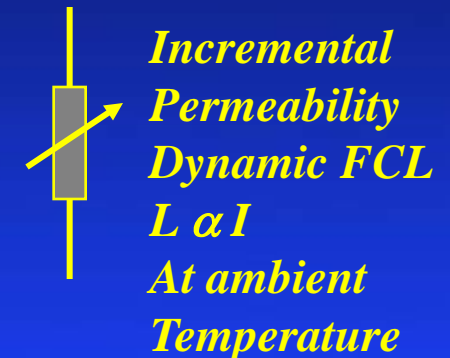
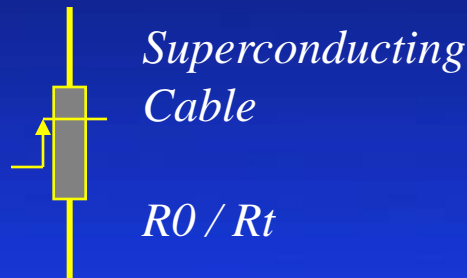
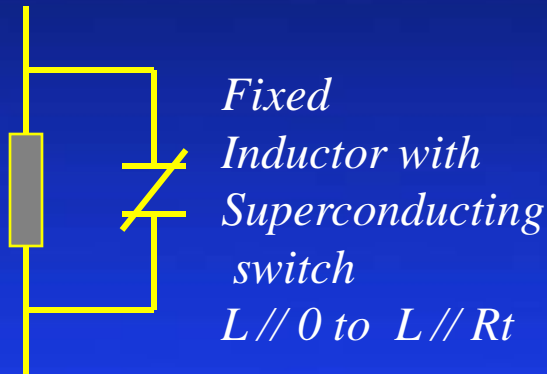
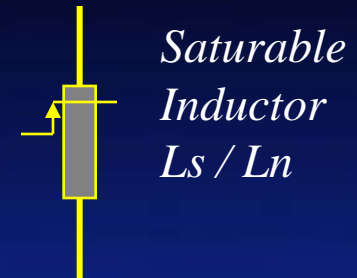
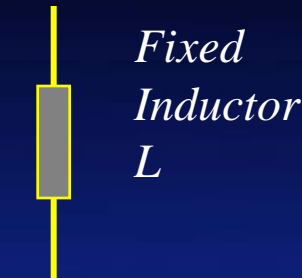
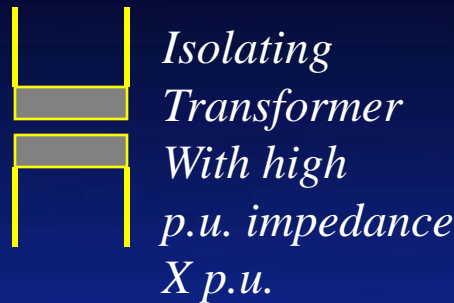

Innovative Electromagnetic Dynamic fault current Limiter

Prafulla Deo & Tushar Shah

Reasons for High short circuit currents

- *Large source capacity*



- *Interconnected networks for redundancy and reliability*



- *Distributed Generation*



- *Contribution to fault from large motors*

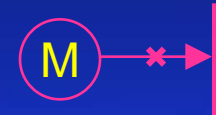

- *Large PF correction capacitors on Line*

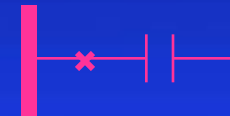

The ideal Fault current limiter -

- *Fast response time*
- *Limit the first peak as well as rms short circuit current*
- *Should operate in wide ambient variations without external cooling or controlled atmosphere*
- *Should respond directly to the short circuit current without depending upon separate supply or signal*
- *Very good reliability and repeatability*
- *Should limit current to low value and still allow discrimination and relay coordination. Avoid “ Fault Hanging ”*

Innovative Electromagnetic Dynamic fault current Limiter
Prafulla Deo & Tushar Shah

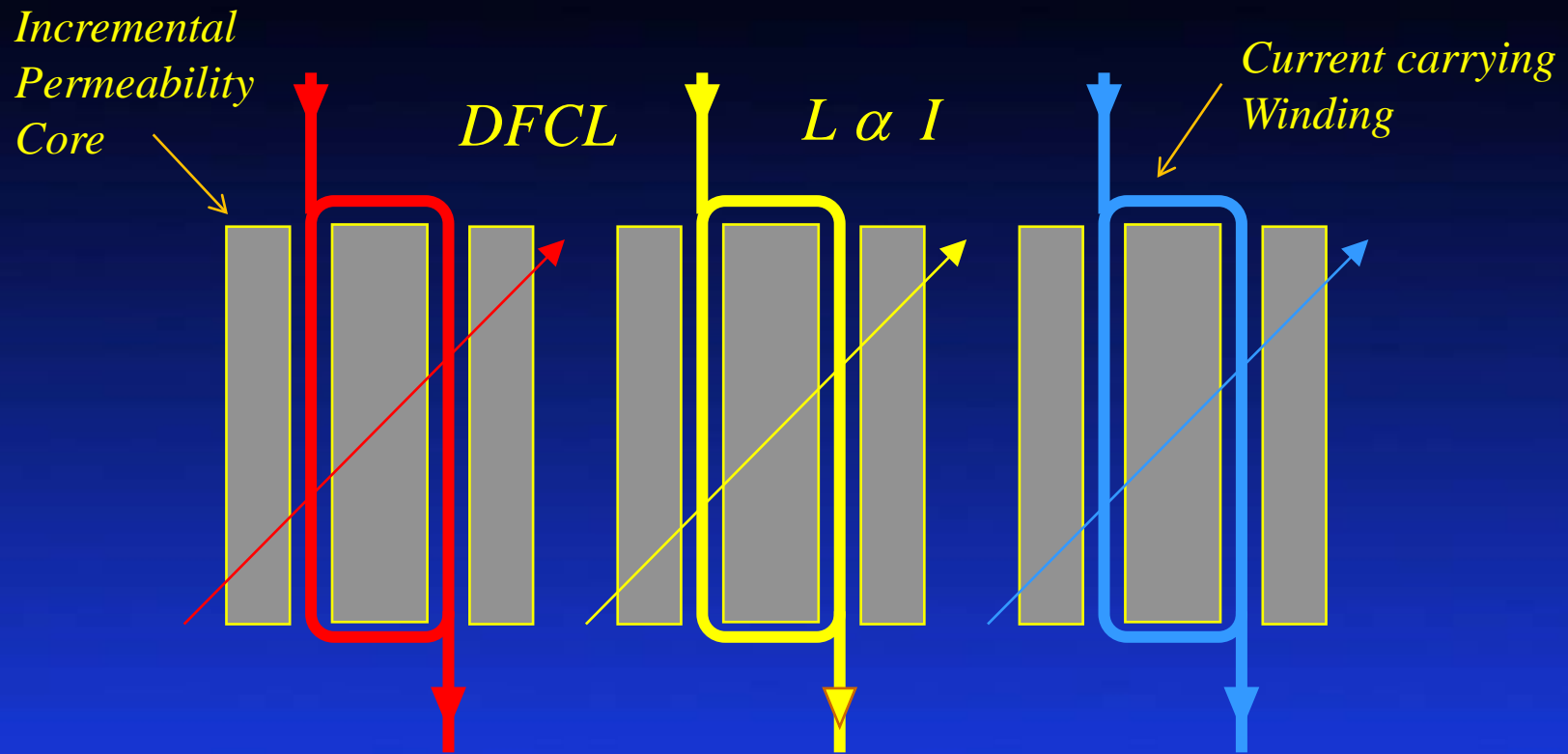

*3 phase schematic construction of the
Dynamic fault current limiter*

Innovative Electromagnetic Dynamic fault current Limiter
Prafulla Deo & Tushar Shah

Present status of Dynamic FCL –

- 1. Voltage range - 15 KV tested and installed commercially
138 KV under validation*
- 2. Nominal current – 1000 amps tested and installed commercially
4000 A under validation*
- 3. Short circuit limiting ratio – Reduction Achieved 7 max. (14% of
(rms) prospective short circuit current)*
- 4. 1st peak limiting – similar to rms reduction ratio*
- 5. Response time – Less than quarter cycle – Set ON
Less than 1 cycle Auto-Reset*
- 6. Short circuit withstand – 3 short circuits of 3 second duration
consecutive.*
- 7. Cooling – Air Natural at normal ambient -20 deg C to + 50 deg C
(- 4 deg F to + 122 deg F)*
- 8. Epoxy Resin cast dry type design*
- 9. Connection options – Cable Box , Flanged bus duct*

*Innovative Electromagnetic Dynamic fault current Limiter
Prafulla Deo & Tushar Shah*

16 KA rms to 6 KA rms with DFCL

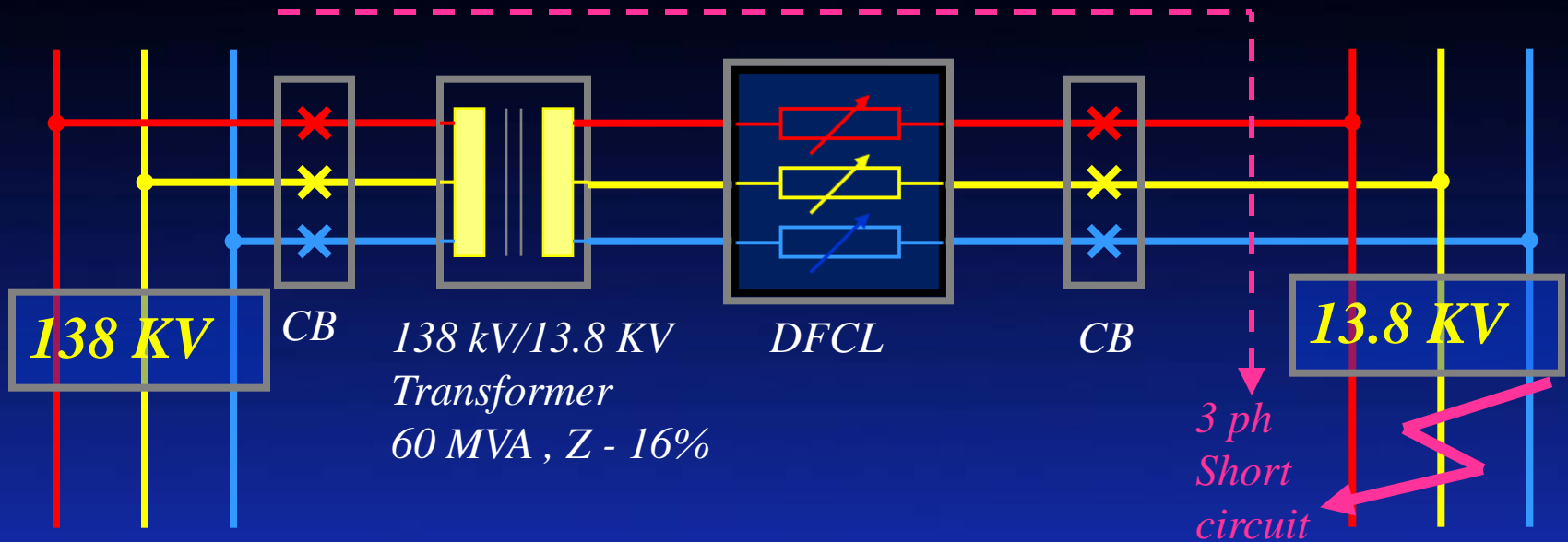

Case 1 – Single transformer 138 / 13.8 KV , 60 MVA Z - 16%

*Down stream 3 ph fault - 45 KA peak , 16 KA rms without DFCL
- 16 KA peak , 6 KA rms with DFCL*

Innovative Electromagnetic Dynamic fault current Limiter
Prafulla Deo & Tushar Shah

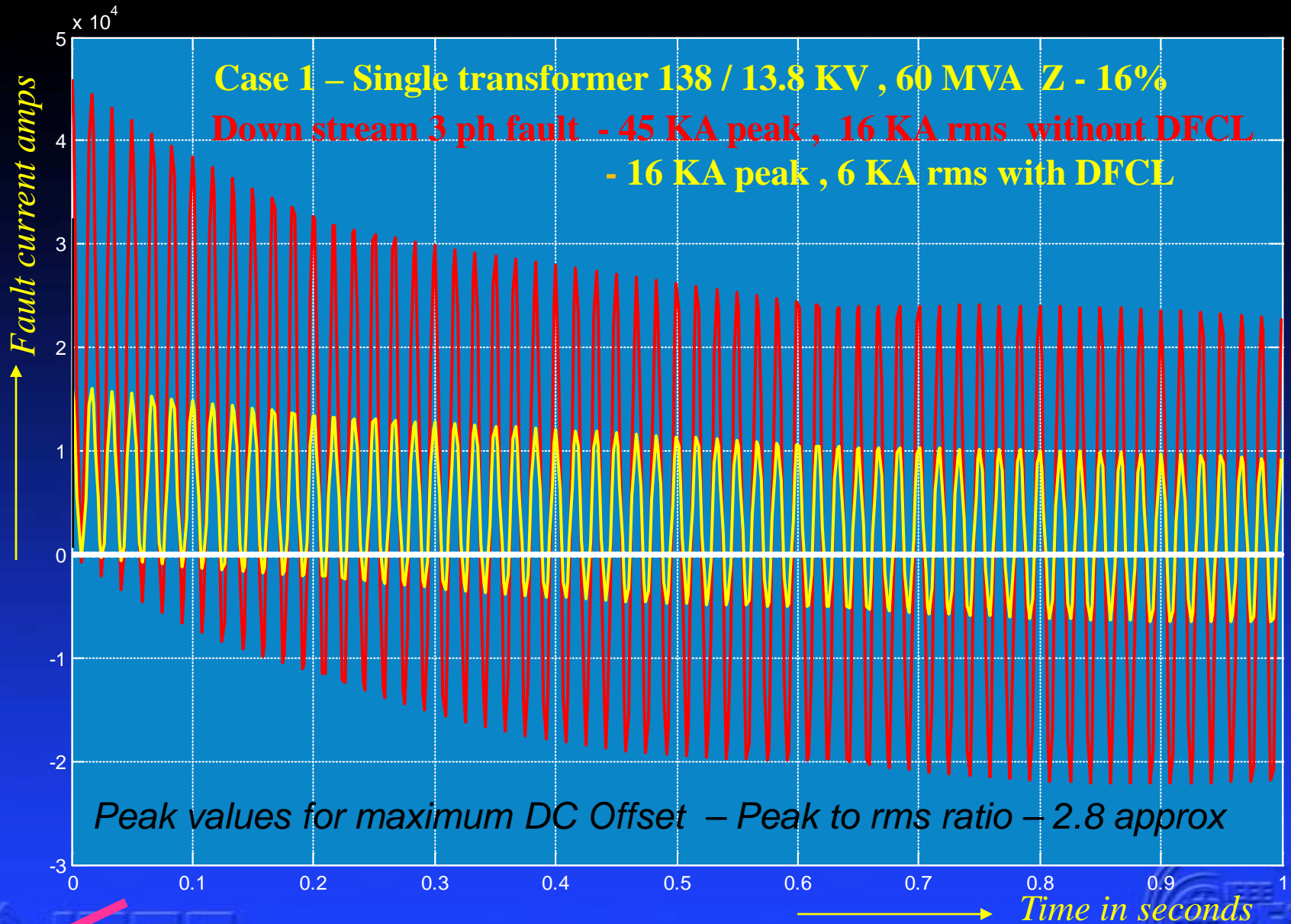

Prospective and limited fault current waveforms



Innovative Electromagnetic Dynamic fault current Limiter Prafulla Deo & Tushar Shah

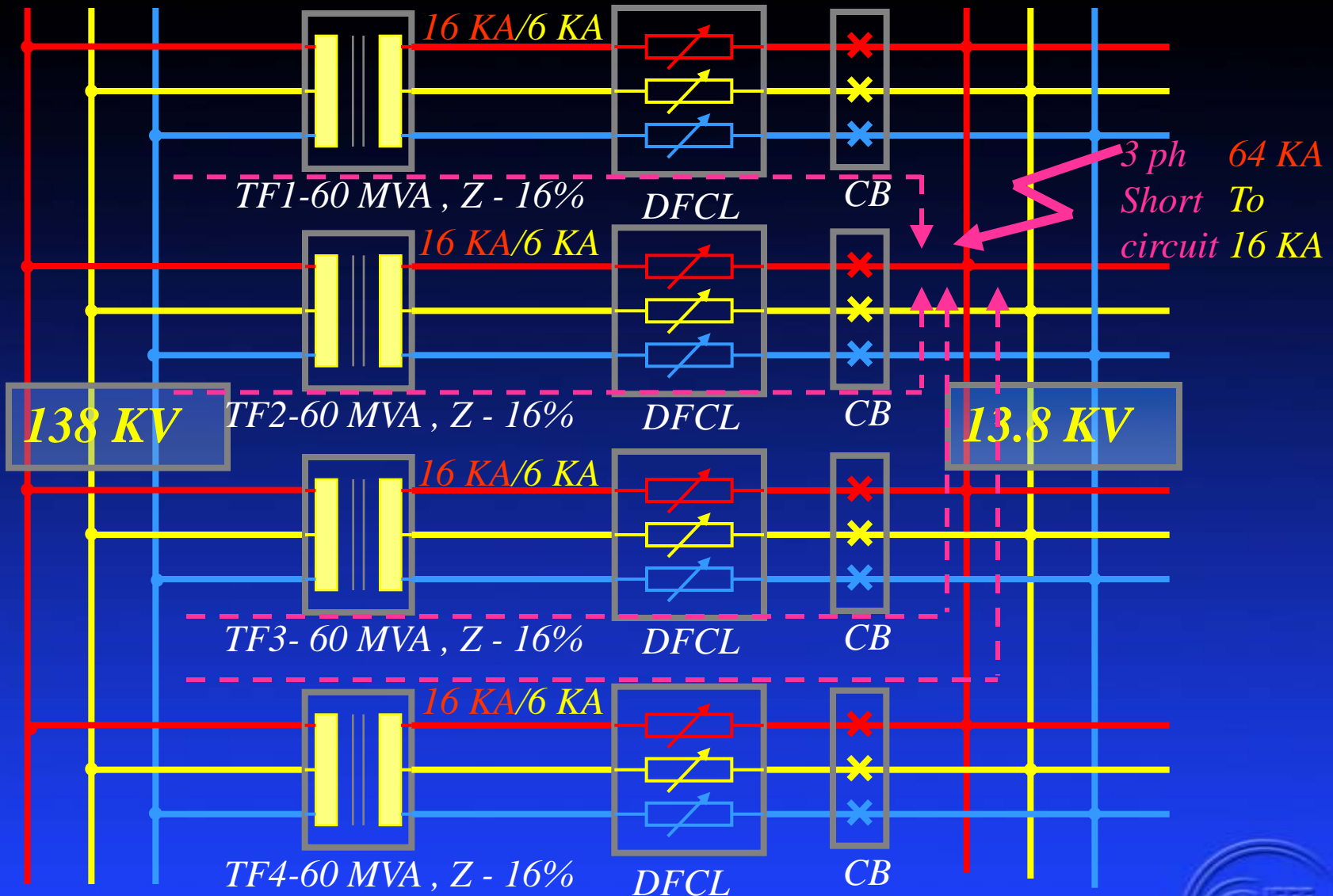

Innovative Electromagnetic Dynamic fault current Limiter
Prafulla Deo & Tushar Shah

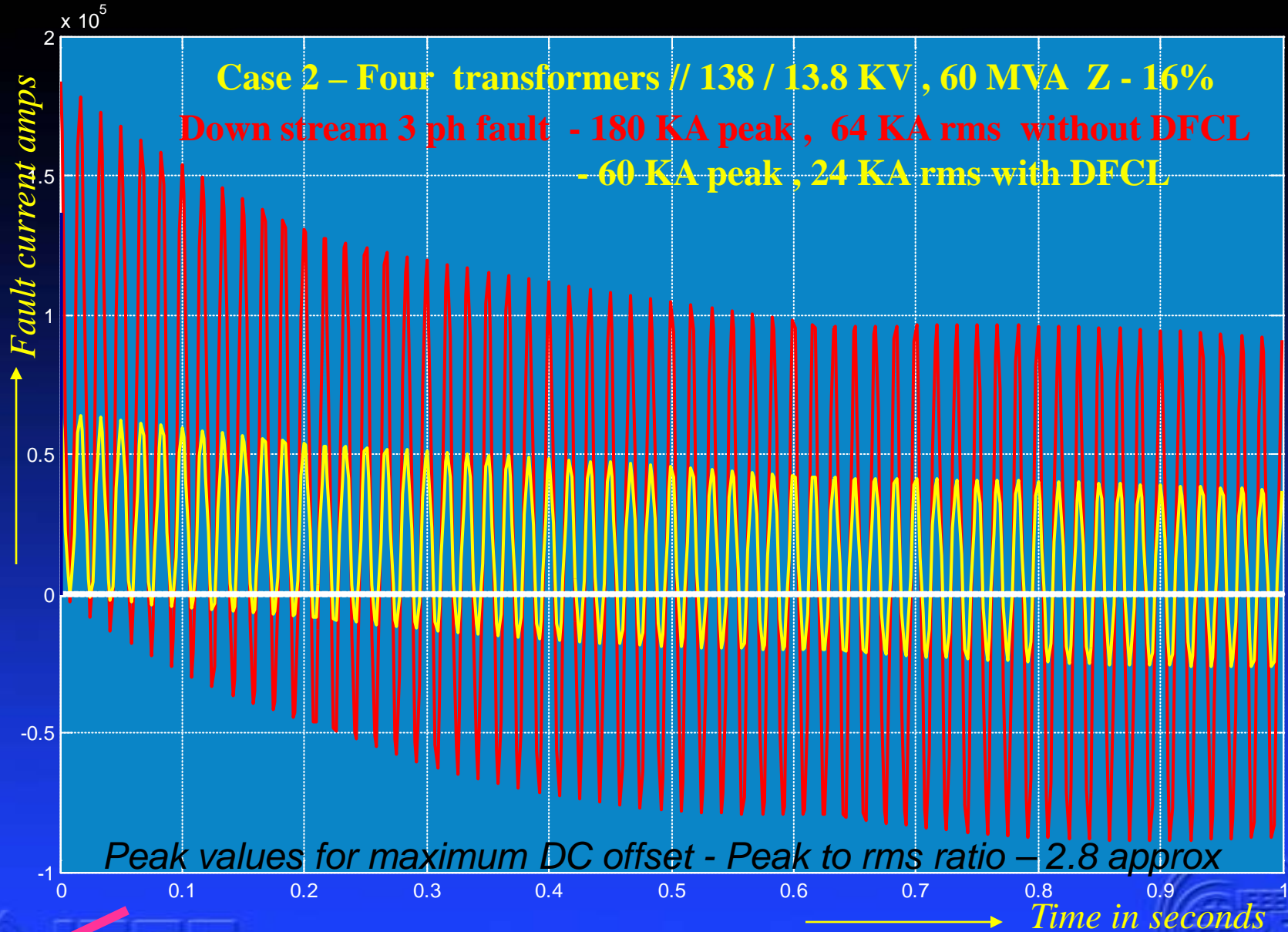

Prospective and limited fault current waveforms

*Innovative Electromagnetic Dynamic fault current Limiter
Prafulla Deo & Tushar Shah*

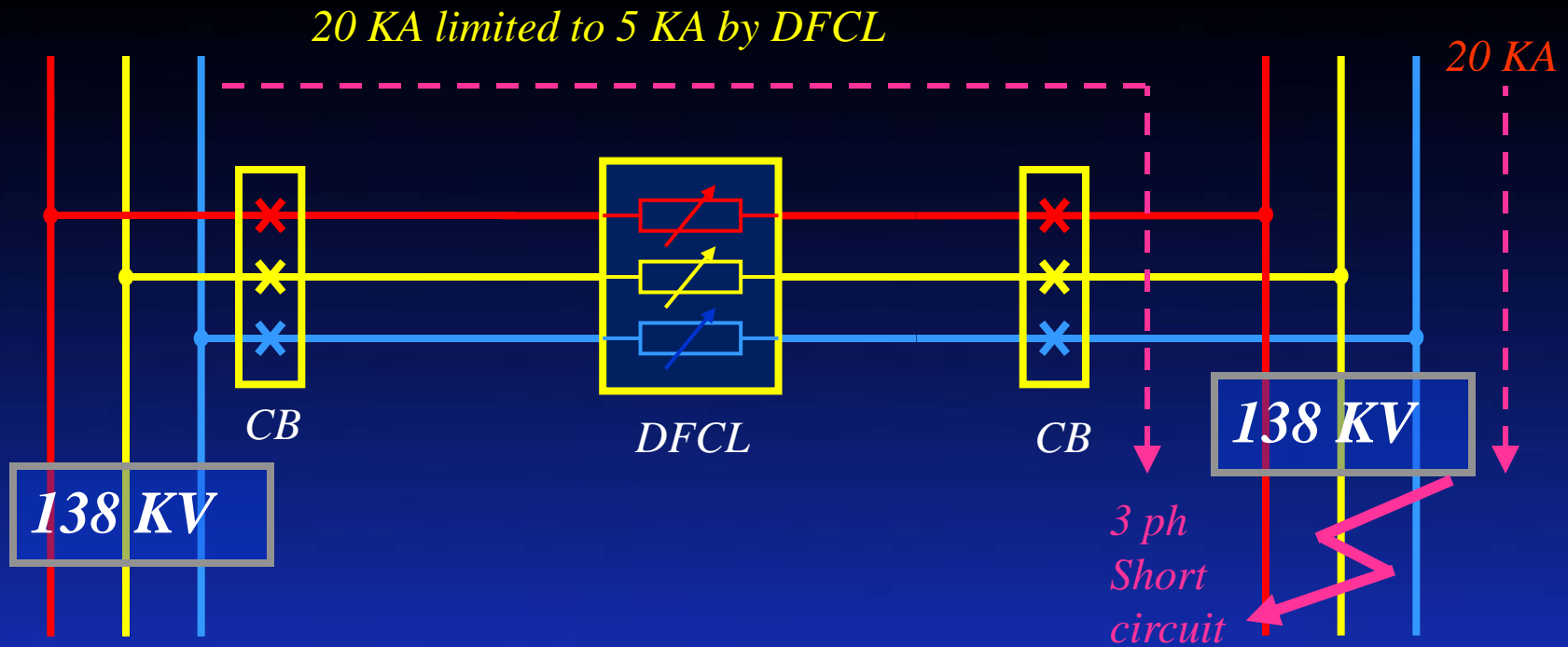

*Case 3 – DFCL on 138 KV bus tie for bi-directional current limit
Down stream 3 ph fault - 100 KA peak , 40 KA rms without DFCL
- 55 KA peak , 25 KA rms with DFCL for
fault on either supply line*

***Innovative Electromagnetic Dynamic fault current Limiter
Prafulla Deo & Tushar Shah***

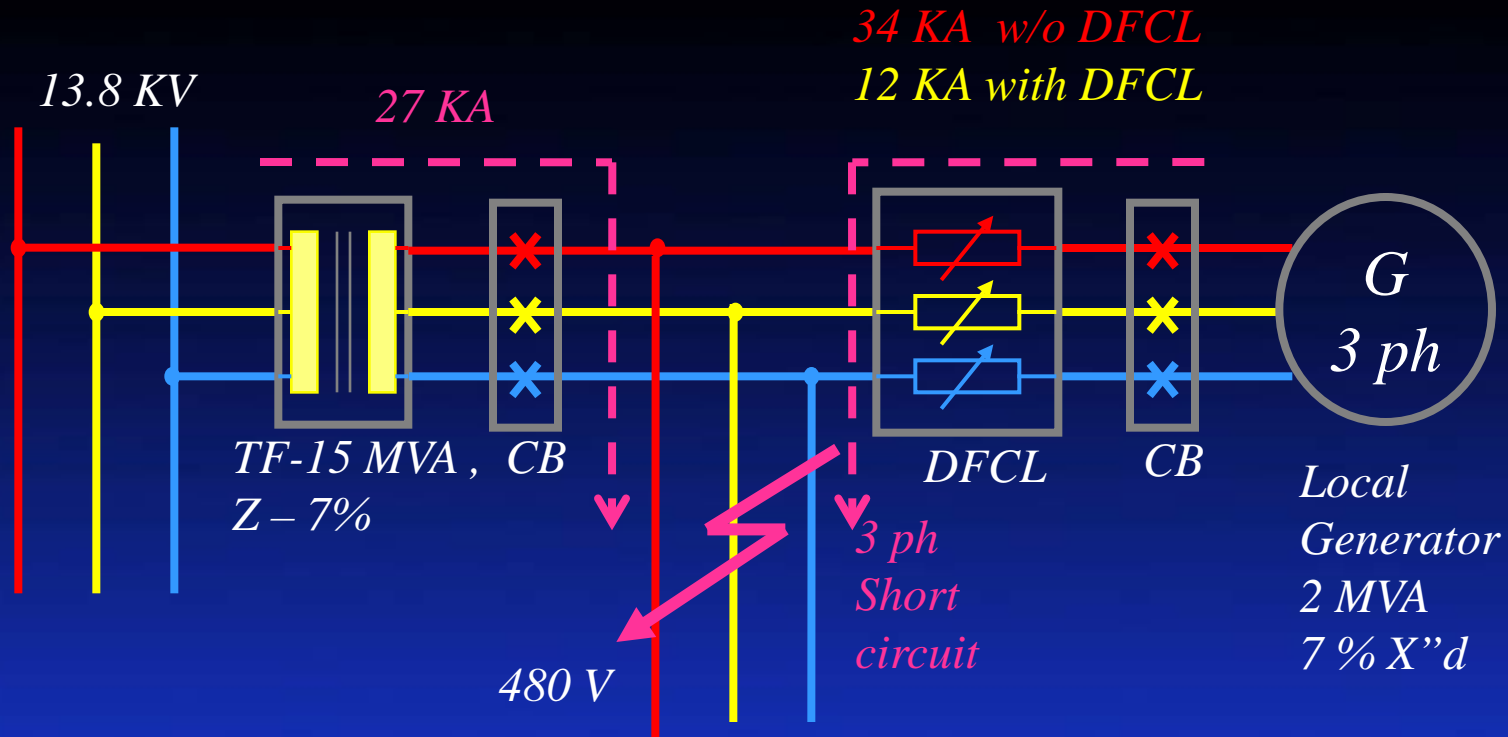

***Case 4- Distributed generation . Local Generation in parallel with Utility
Down stream 3 ph fault - 150KA peak , 61KA rms without DFCL
- 100 KA peak , 39 KA rms with DFCL***

*Innovative Electromagnetic Dynamic fault current Limiter
Prafulla Deo & Tushar Shah*

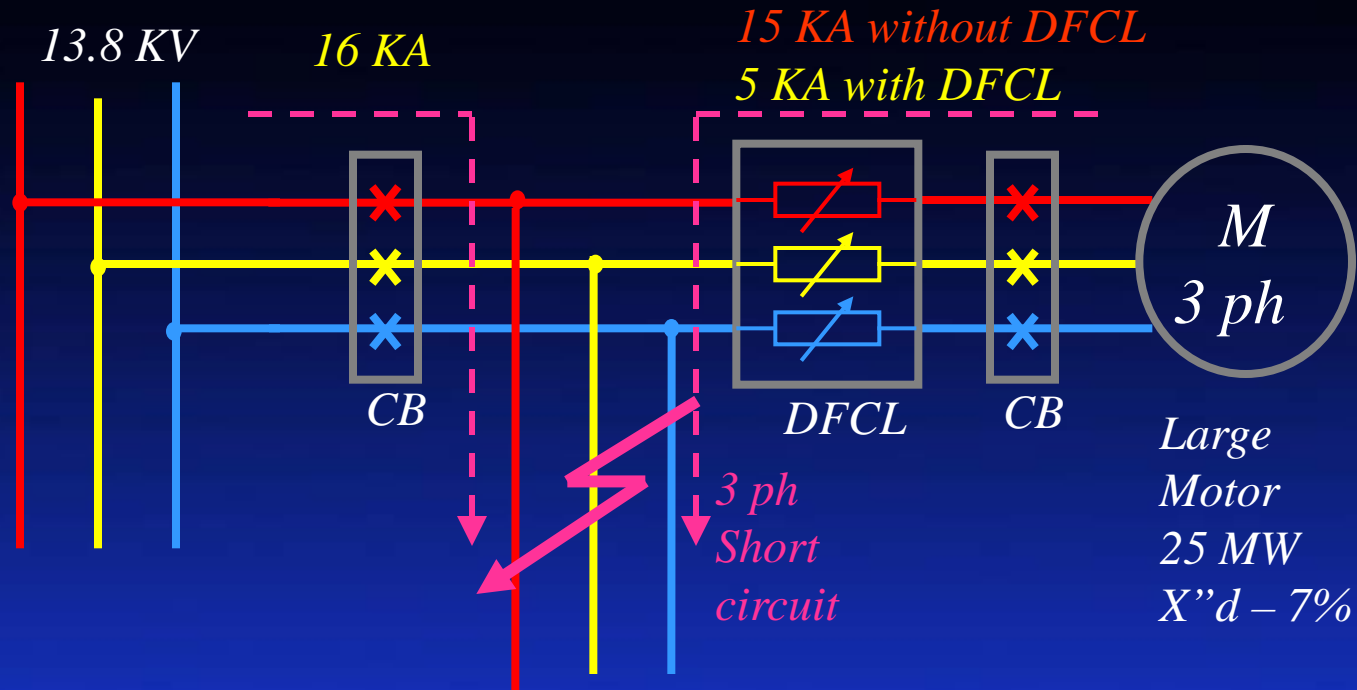

Case 4- Reduction in Fault contribution from Large motors

*Down stream 3 ph fault - 70 KA peak , 31 KA rms without DFCL
- 46 KA peak , 21 KA rms with DFCL*

*Innovative Electromagnetic Dynamic fault current Limiter
Prafulla Deo & Tushar Shah*

Unprocessed core

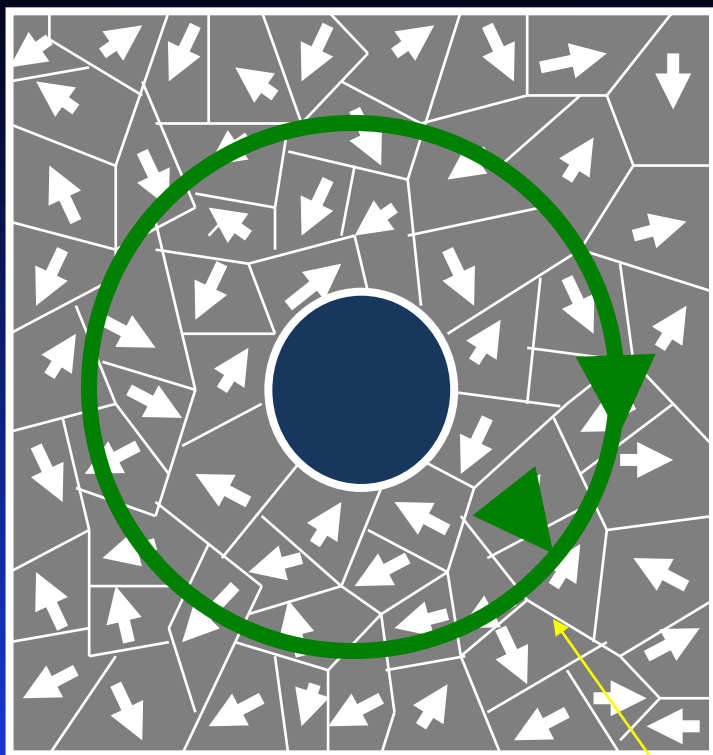

*Randomly aligned domains
in the unprocessed core*

DFCL core

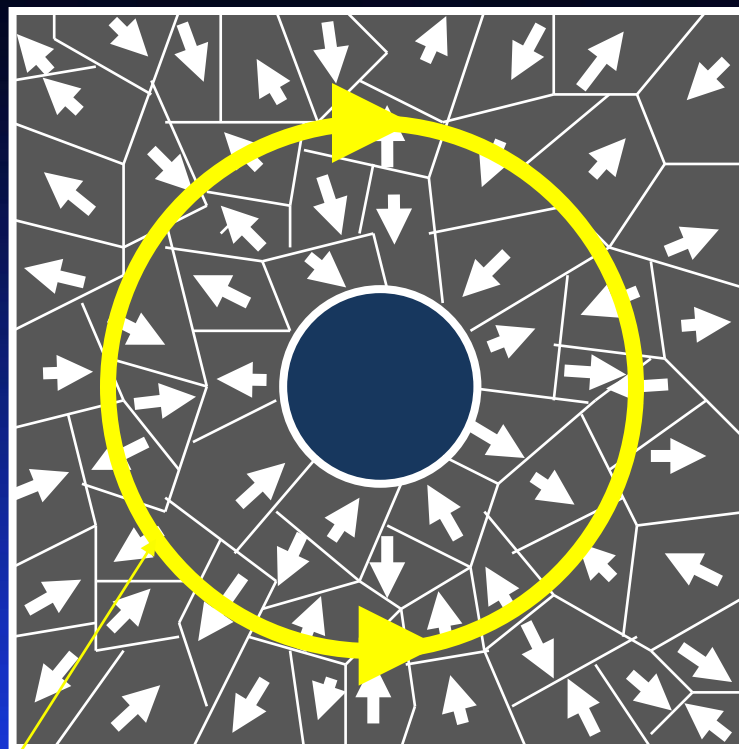

*Radially pre-aligned domains
in the processed core*

*Circumferential
Flux*

Innovative Electromagnetic Dynamic fault current Limiter
Prafulla Deo & Tushar Shah

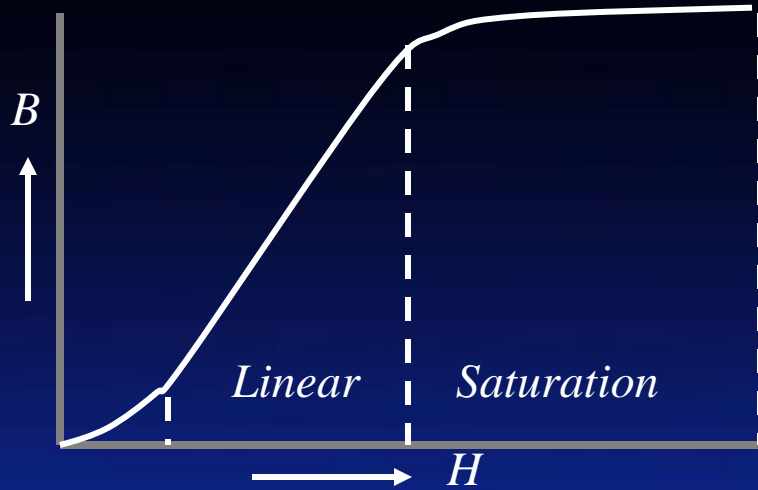

*Near constant permeability
of conventional core*

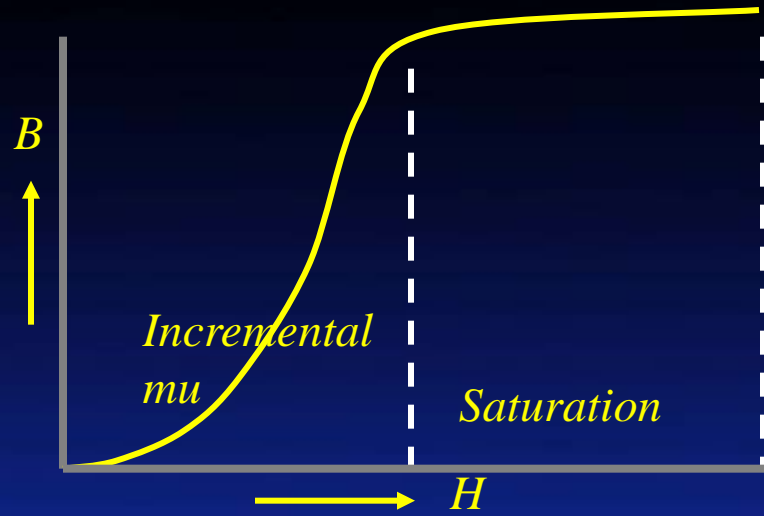

*Incremental permeability
of DFCL core*

Magnetization curves for the DFCL core

Toroidal per phase winding of the Electromagnetic DFCL

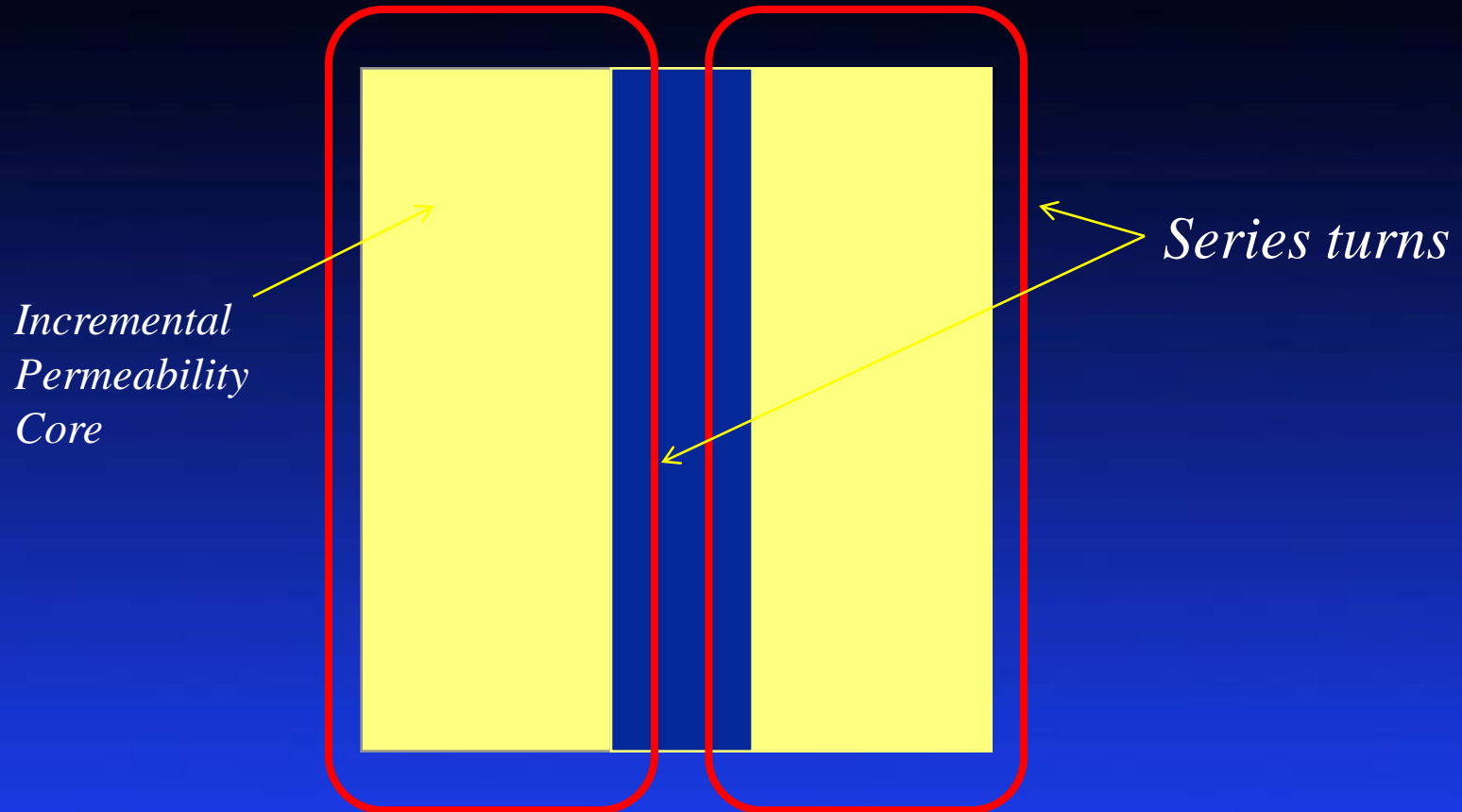

Sectional view

Salient Features of the incremental permeability Electromagnetic DFCL

- Impedance increases with fault current. Thus short circuit current is limited in a narrow band for different fault and source impedances*
- Can work with Air natural cooling. No requirement of cryogenic cooling*
- Simple and rugged in construction.*
- Failure if at all to high impedance mode which will increase the normal voltage drop and is easily detected*

Innovative Electromagnetic Dynamic fault current Limiter
Prafulla Deo & Tushar Shah

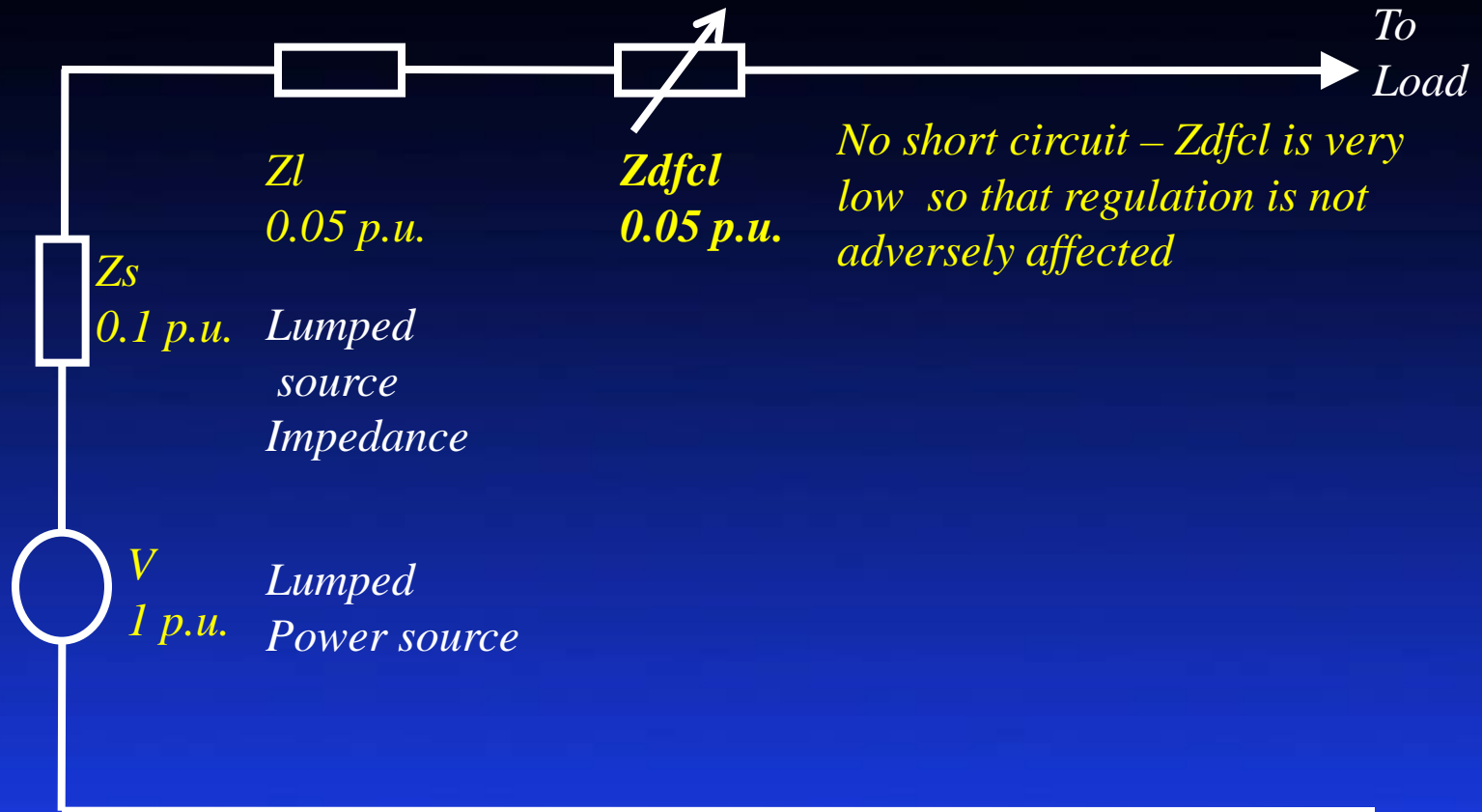

Impedance behavior of DFCL for healthy network pre-fault or post fault-clearance

***Innovative Electromagnetic Dynamic fault current Limiter
Prafulla Deo & Tushar Shah***

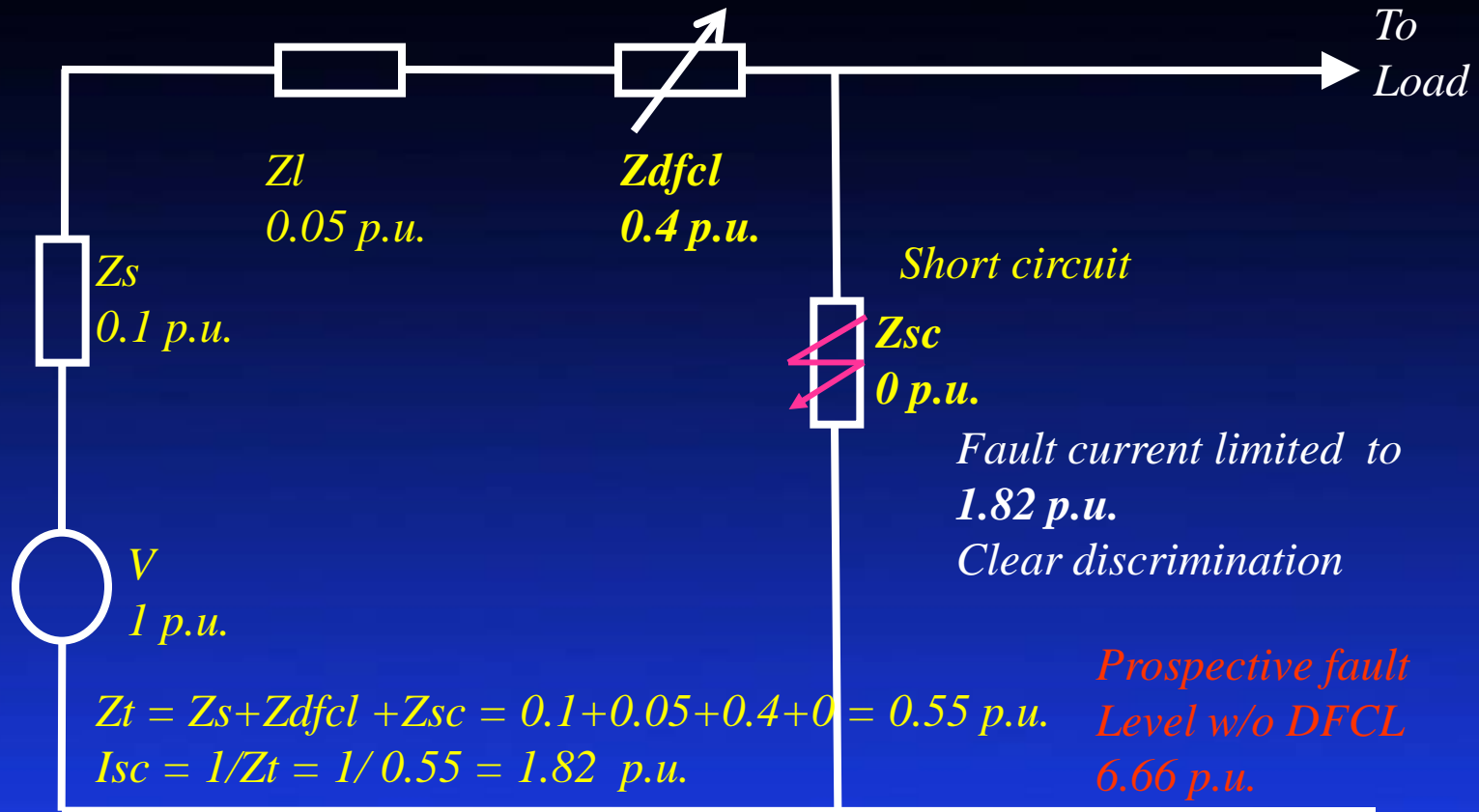

Impedance behavior of DFCL with a low impedance fault – bolted short circuit

*Innovative Electromagnetic Dynamic fault current Limiter
Prafulla Deo & Tushar Shah*

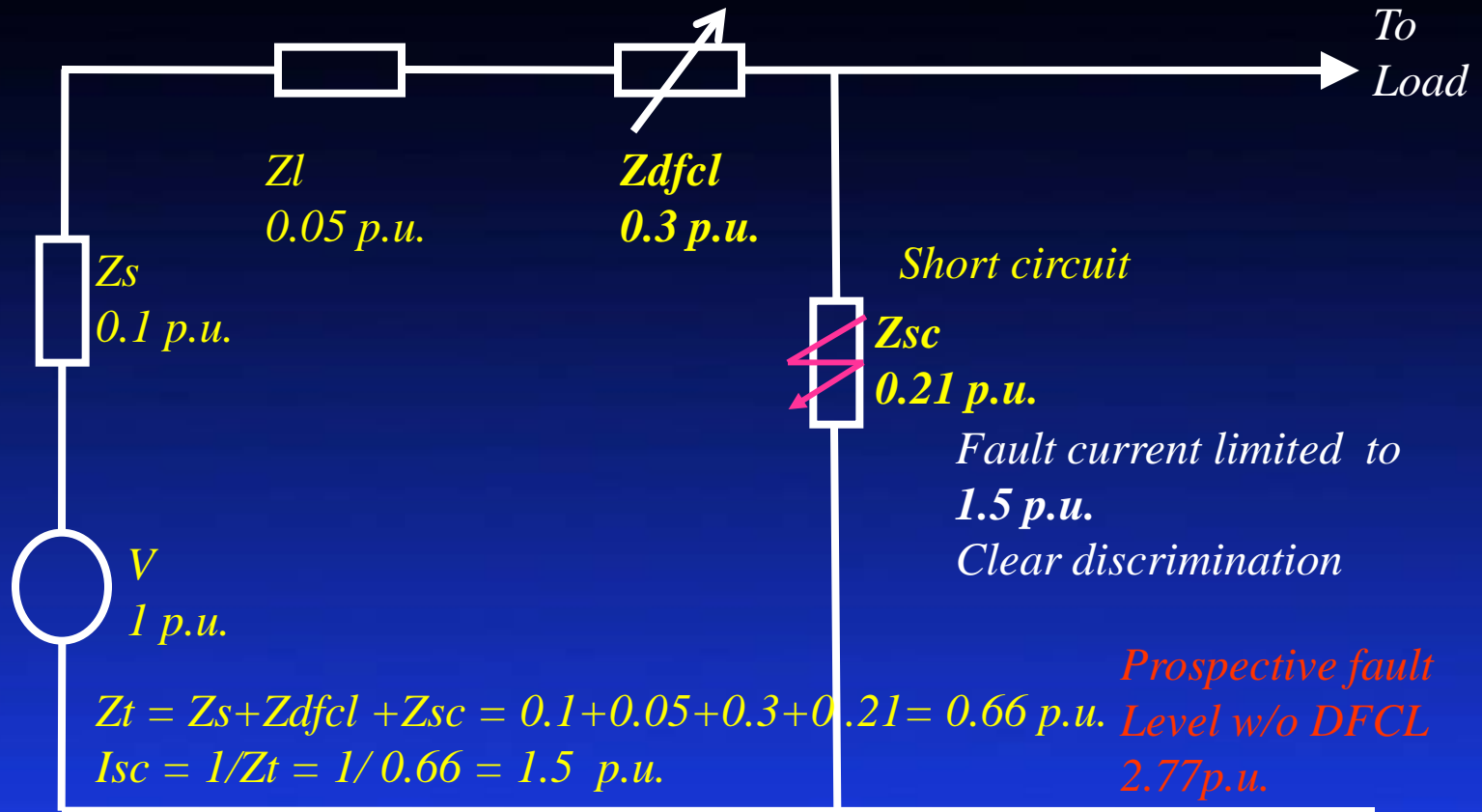

Impedance behavior of DFCL with a medium impedance fault

Innovative Electromagnetic Dynamic fault current Limiter
Prafulla Deo & Tushar Shah

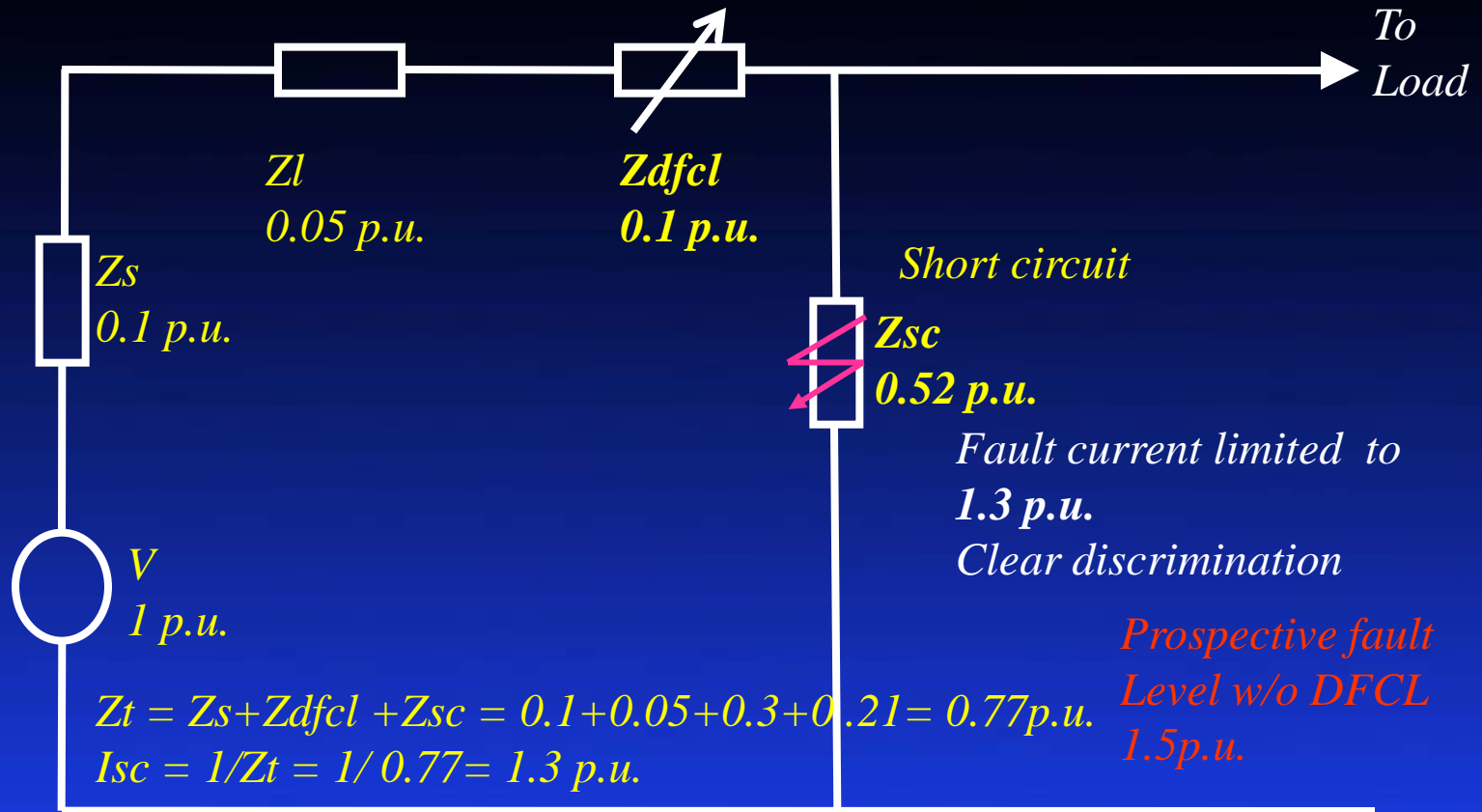

Impedance behavior of DFCL with a high impedance fault

Innovative Electromagnetic Dynamic fault current Limiter

Prafulla Deo & Tushar Shah

<i>Z_{sc}</i>	<i>Z_{dfcl}</i>	<i>Fault currents in p.u. Z_s – 0.1 p.u. Z_l – 0.05 p.u.</i>					<i>I_{sc} with no Limiter</i>	
		<i>DFCL current limit</i>	<i>Impedance of fixed inductor with or without Superconducting switch</i>					
			<i>0.07</i>	<i>0.15</i>	<i>0.2</i>	<i>0.25</i>		<i>0.3</i>
<i>0</i>	<i>0.4</i>	<i>1.82</i>	<i>4.55</i>	<i>3.33</i>	<i>2.86</i>	<i>2.5</i>	<i>2.22</i>	<i>6.67</i>
<i>0.2</i>	<i>0.3</i>	<i>1.54</i>	<i>2.38</i>	<i>2</i>	<i>1.82</i>	<i>1.67</i>	<i>1.54</i>	<i>2.86</i>
<i>0.3</i>	<i>0.25</i>	<i>1.43</i>	<i>1.92</i>	<i>1.67</i>	<i>1.54</i>	<i>1.43</i>	<i>1.33</i>	<i>2.22</i>
<i>0.4</i>	<i>0.18</i>	<i>1.37</i>	<i>1.61</i>	<i>1.43</i>	<i>1.33</i>	<i>1.25</i>	<i>1.18</i>	<i>1.82</i>
<i>0.5</i>	<i>0.1</i>	<i>1.33</i>	<i>1.39</i>	<i>1.25</i>	<i>1.18</i>	<i>1.11</i>	<i>1.05</i>	<i>1.54</i>

Illustrative example of Fault currents with DFCL & with fixed impedance Inductor with our without Superconducting switch

Innovative Electromagnetic Dynamic fault current Limiter
Prafulla Deo & Tushar Shah

prafulla.deo@InnovativeTechUSA.com

tushar.shah@InnovativeTechUSA.com

Thank you