



## Reducing Transmission Investment to Meet Renewable Portfolio Standards Using Controlled Energy Flows

PES Conference on Innovative Smart Grid Technologies Conference  
January 22, 2010

**Prof. Deepak Divan**

**Frank Kreikebaum**

**Debrup Das**

Intelligent Power Infrastructure Consortium

School of Electrical Engineering

Georgia Institute of Technology

777 Atlantic Drive NW  
Atlanta, GA

[deepak.divan@ece.gatech.edu](mailto:deepak.divan@ece.gatech.edu)



## Overview of Renewable Portfolio Standards

- Renewable Portfolio Standards (RPS) have been adopted in the majority of US states
  - Binding in 27 states plus DC
  - Non-binding in 5 states – but “voluntary” performance impacts rate cases to varying degrees
- Waxman-Markey requires 20% of national energy be met with combination of renewables and efficiency by 2020 (Minimum renewable content of 5%)
- RPS mandates and other pro-renewable policies (RGGI, green choice mandates) are driven by a number of factors:
  - Increasing concentration of greenhouse gases
  - Heightened demand for fossil fuels
  - National security concerns

State	RPS Level (Percent State Energy Usage or Capacity)	By	Wind Capacity to Satisfy RPS (GW)	State	RPS Level (Percent State Energy Usage or Capacity)	By	Wind Capacity to Satisfy RPS (GW)
AZ	15%	2025	8.40	NJ	23%	2021	6.97
CA	33%	2030	34.40	NM	20%	2020	3.56
CO	20%	2020	5.33	NV	20%	2015	3.23
CT	23%	2020	3.77	NY	24%	2013	17.31
DC	20%	2020	0.01	NC	13%	2021	8.04
DE	20%	2019	0.84	<b>ND</b>	<b>10%</b>	<b>2015</b>	<b>1.54</b>
HI	20%	2020	1.14	OR	25%	2025	6.81
IA	0.105 GW		0.11	PA	8%	2020	8.94
IL	25%	2025	24.75	RI	16%	2019	0.56
MA	15%	2020	3.49	<b>SD</b>	<b>10%</b>	<b>2015</b>	<b>0.30</b>
MD	20%	2022	4.96	TX	5.8 GW	2015	5.80
ME	40%	2017	3.19	<b>UT</b>	<b>20%</b>	<b>2025</b>	<b>4.49</b>
MI	10%	2015	5.90	<b>VT</b>	<b>10%</b>	<b>2013</b>	<b>0.29</b>
MN	25%	2025	6.73	<b>VA</b>	<b>12%</b>	<b>2022</b>	<b>4.65</b>
MO	15%	2021	6.76	WA	15%	2020	7.93
MT	15%	2015	2.15	WI	10%	2015	3.13
NH	24%	2025	2.74				

Meeting existing state RPS mandates with wind is projected to require 200 GW of wind capacity in 2030 - 25 GW installed today. Existing RPS + Waxman-Markey could require up to 360 GW of wind capacity.



# Simulation Setup

- Split IEEE 39 Bus System into four, geographically distant regions (NW, NE, SW, SE)
- Each region assigned a 6-period historical average daily load profile NW (NYISO), NE (MISO-Central), SW (SERC), SE (PJM); aggregate peak of 4880 MW
- Coal-dominated generation with only 1% of annual energy initially sourced from wind
- Coal plants assigned realistic cost curves
- Wind plants assigned the 6-period stochastic wind profiles of SPP (gen 10) and MISO-WEST (Gen 8) derived from the NREL Eastern Wind Integration and Trans. Study
- Load growth of 2 % applied to all load buses equally
- RPS imposed system wide: 1 percentage point increase per year
- Single OPF used to solve all four regions
- Line ratings and generation ratings set so the majority of energy is generated and used in the same region

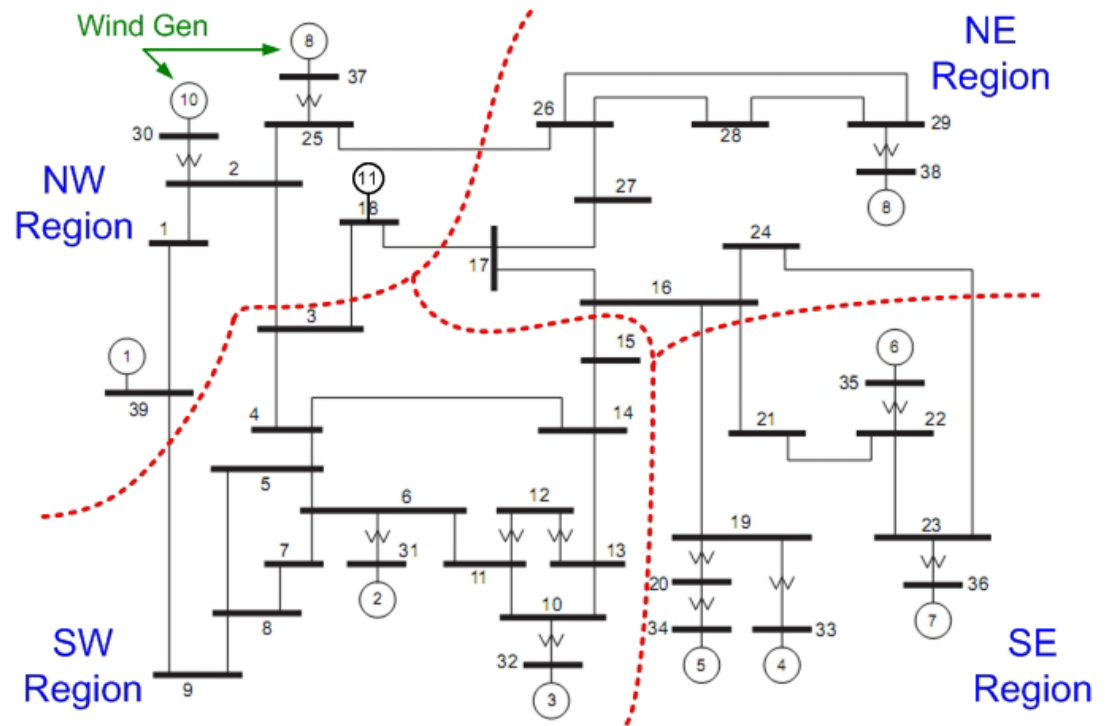

# The Challenge of Power Flow Control with OPF

- Possible to increase ATC by dispatching incremental power flows down lightly loaded paths once primary paths are constrained
- The figure shows a desired 20 MW incremental dispatch. Only 1.5 MW reaches the target bus. Increased flows on non-path lines limit scope for an increase of ATC
- Without power flow control, goal of increasing ATC while maintaining reliability requires new line construction – keeping overall system utilization low.

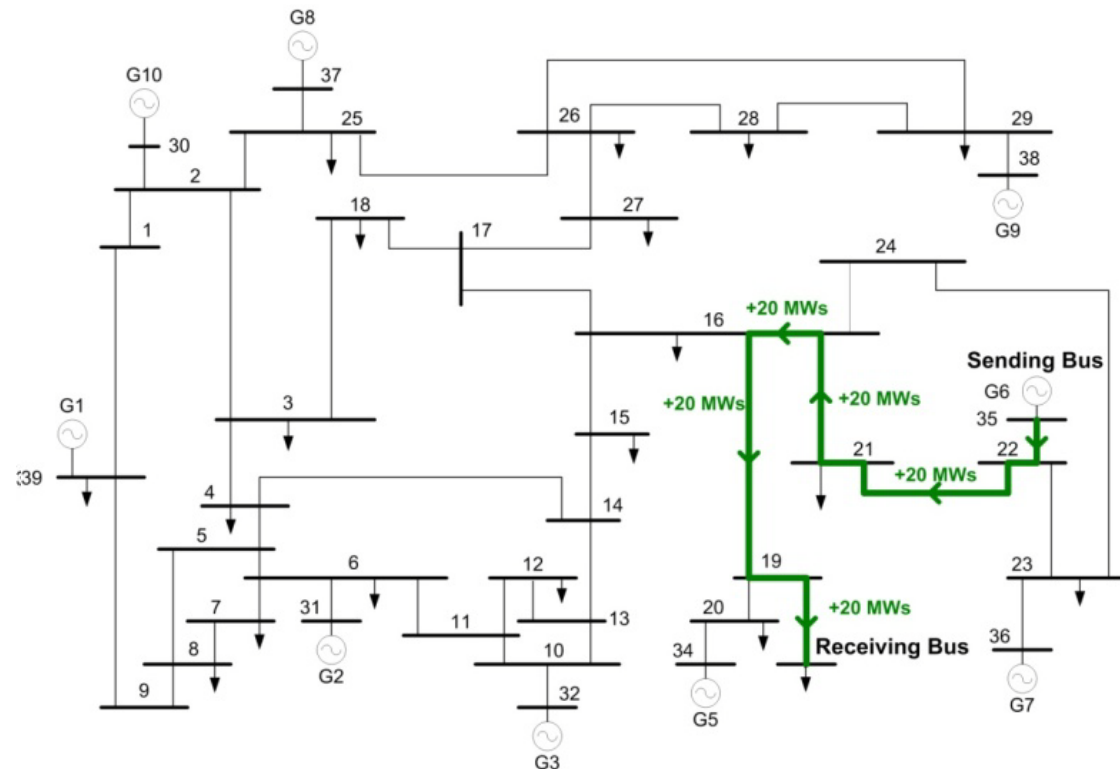

# Controllable Energy Flow (CEF) Concept

**Goal:** Dispatch incremental power flow along a transaction path without changing existing flows on adjacent paths

- In the absence of control - each additional MW of dispatched energy changes:
  - Node voltages
  - Line flows
- To maintain pre-transaction power flows, node voltages at branch-out points must remain unaltered

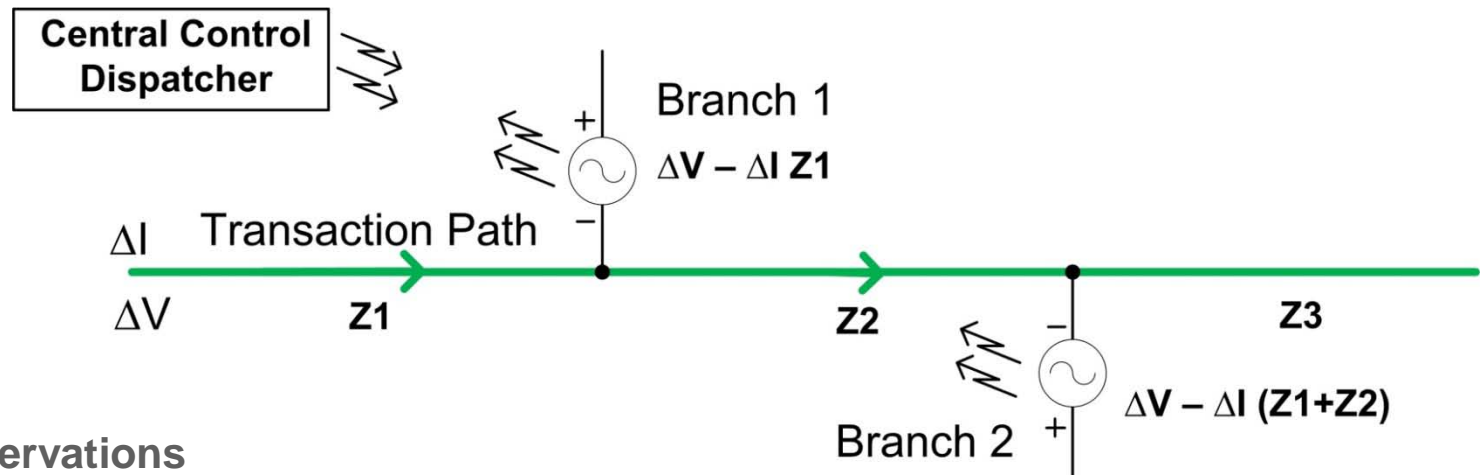

## Observations

- Compensation voltages are small - only compensating for the series drop along the transaction path
- Complete compensation requires a real and reactive component
- Compensation only on the line to be controlled → Investor retains benefits of investment



# Realizing CEF

- 20 MW transaction requires total control effort of 3.6 MVA
- Established devices (UPFC) and new technologies (CNT) can realize the compensation necessary for CEF
- CNT augments existing LTC with fractionally-rated converter
- Installation of CNT between two control areas shows P & Q control
- CEF provides dynamic control of power flows

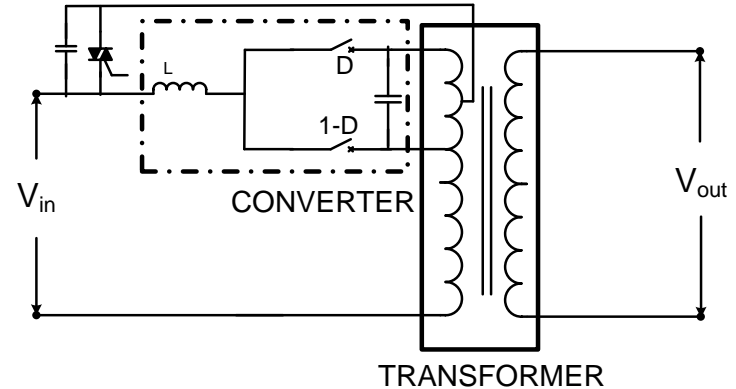

**Controllable Network Transformer (CNT)**

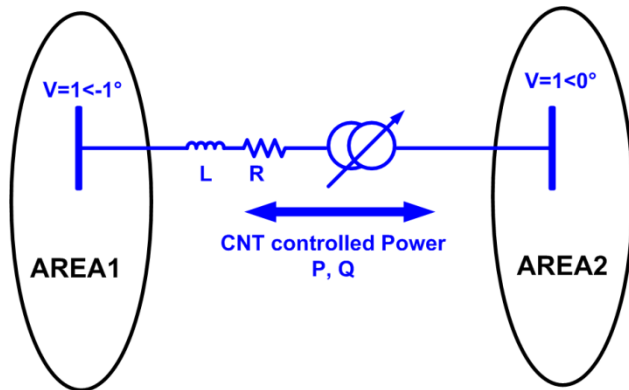

**System to Demonstrate CNT Functionality**

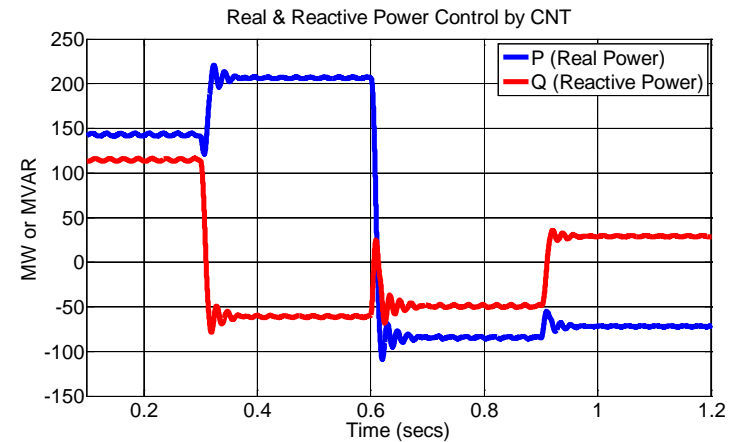

**CNT Control of Real and Reactive Power**



# Transmission Investment Simulation

**GOAL:** Simulate transmission investment over the 20 year RPS phase-in window with and without the use of CEF

- Wind capacity added annually to meet annual RPS increase
- Assumed perfect demand and wind forecasts enable planning certainty
- Simulation simulates system operation and planning process - upgrades facilities until no wind output is curtailed
- Planning stage choices:
  - BAU scenario – line upgrade
  - CEF scenario – line upgrade or install CEF devices
- Operation method:
  - BAU: OPF
  - CEF: OPF of coal plants and CEF of wind plant output

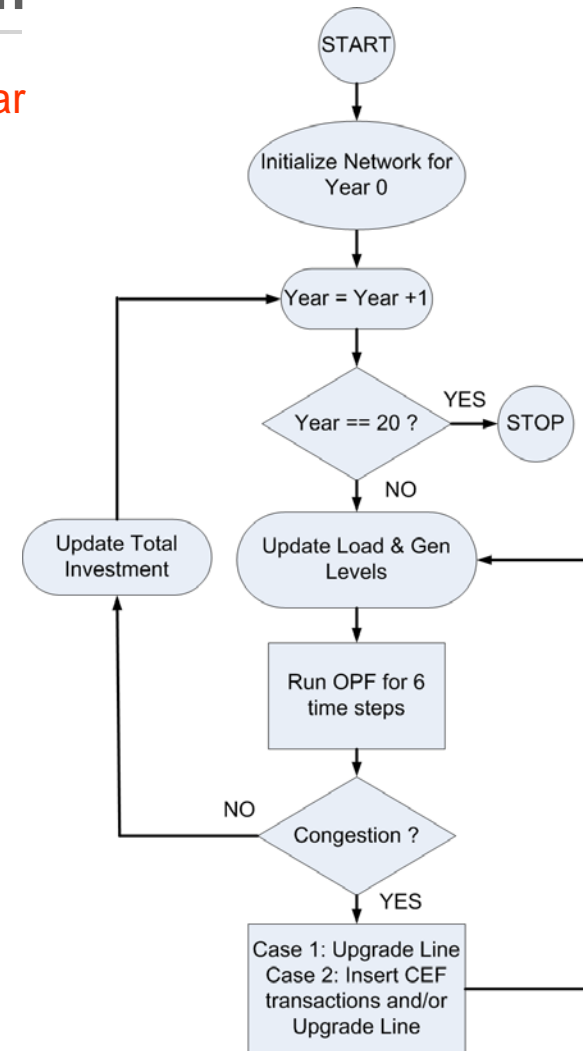

Flowchart for Simulation Methodology



# Comparison of Required Upgrades

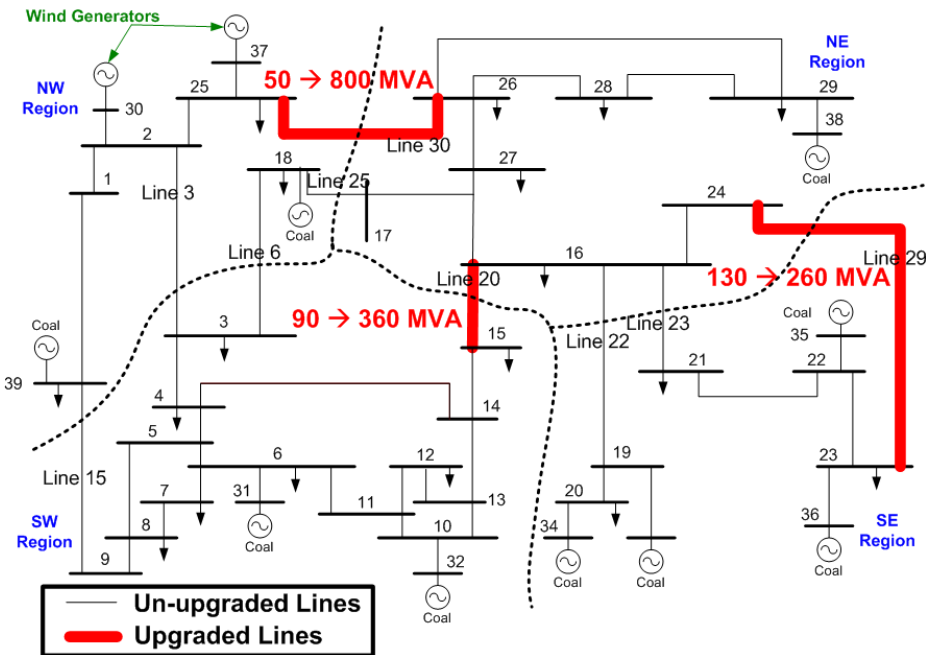

BAU Case

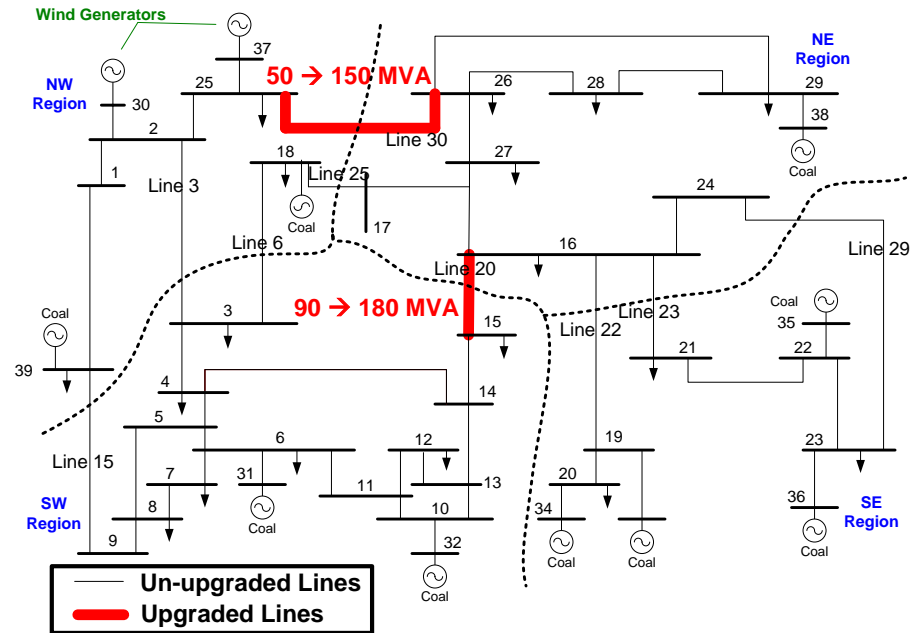

CEF Case

- BAU case requires upgrade of 3 regional tie-lines with a total construction of 186,000 MW-miles of line (Total Cost = \$186M @ \$1000/MW-mile)
- CEF case requires construction of 36,000 MW-miles and installation of 708 MVA of CEF devices (Total Cost \$106M = \$36M + \$70M @\$100/kVA for CEF )



# Investment Comparison and Potential Impact of CEF

## Equivalent Cost to Meet RPS

BAU	\$186 Million/186,000 MW-miles
CEF	\$107 Million/36,000 MW-miles

## Assumptions

- Line cost of \$1000/MW-mile
- CEF device cost of \$100/kVA
- Discount rate of 0%

## Current Realities

- Projected cost to meet RPS mandates are significant . US DOE estimates \$3B/yr for 20 years required to supply 20% of energy with wind in 2030 (against \$4.5 B/yr average annual T&D investment over the last 20 years).
- Cost, line construction delays, and opposition to new lines may curb support for higher levels of renewables
- Non-optimal incentives for merchant transmission to strengthen linkages between renewable regions and load centers

Total Transmission Investment over Time

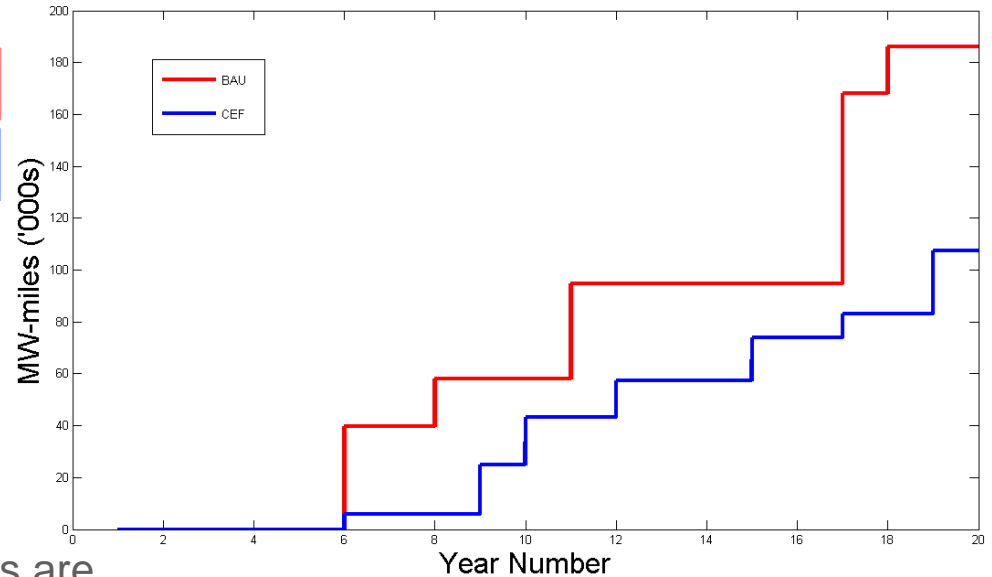

## Potential CEF Impacts

- Cost-effective RPS compliance, more so if discount rates considered
- Reduced line construction
- Faster implementation
- Expanded opportunities for merchant transmission to connect renewables to load centers



## Conclusions

---

- Existing RPS mandates require a minimum of 4x the current wind capacity if met entirely with wind. Federal mandates layered on existing RPS mandates, if met with wind, would require 14x current wind capacity - even more if met with solar.
- Simulation shows significant transmission investment required to meet RPS mandates if renewable resources are sited far from load centers and inter-area tie-lines are weak.
- Cost of RPS compliance may be reduced through Smart Grid Technologies.
- Controllable Energy Flows (CEF) can maximize utilization of existing assets and reduce RPS-compliance cost and public opposition. **Requires only 20% of line build under BAU.**
- Allows incremental deployment, when compared with new line buildout.
- Controllable Network Transformer (CNT) is a new technology able to realize CEF.
- CNT converts an existing dumb asset to a **smart and controllable asset** using a fractionally rated converter.
- Market benefits of CEF - especially potential for CEF to invigorate a 'merchant transmission' market using existing transmission lines - require further study.

