



Dynamic Monitoring and Decision Systems (DYMONDS) for Smart Grids: The Missing Link

©Marija Ilic

ECE and EPP, Professor CMU milic@ece.cmu.edu

January 21, 2010

The IEEE Conference on Smart Grids

Outline

- Quick summary of today's operating and planning practices (stress on SCADA)
- **Smart Grids**: A means of enabling customer choice in coordination with societal objectives; enabling innovation.
- The key question: What information to exchange, why and how?
- DYMONDS-enabled monitoring and decision making (transformed SCADA)
- IT-enabled Rules, Rights and Responsibilities (3Rs) – **Smart Regulation**

Today's power grid

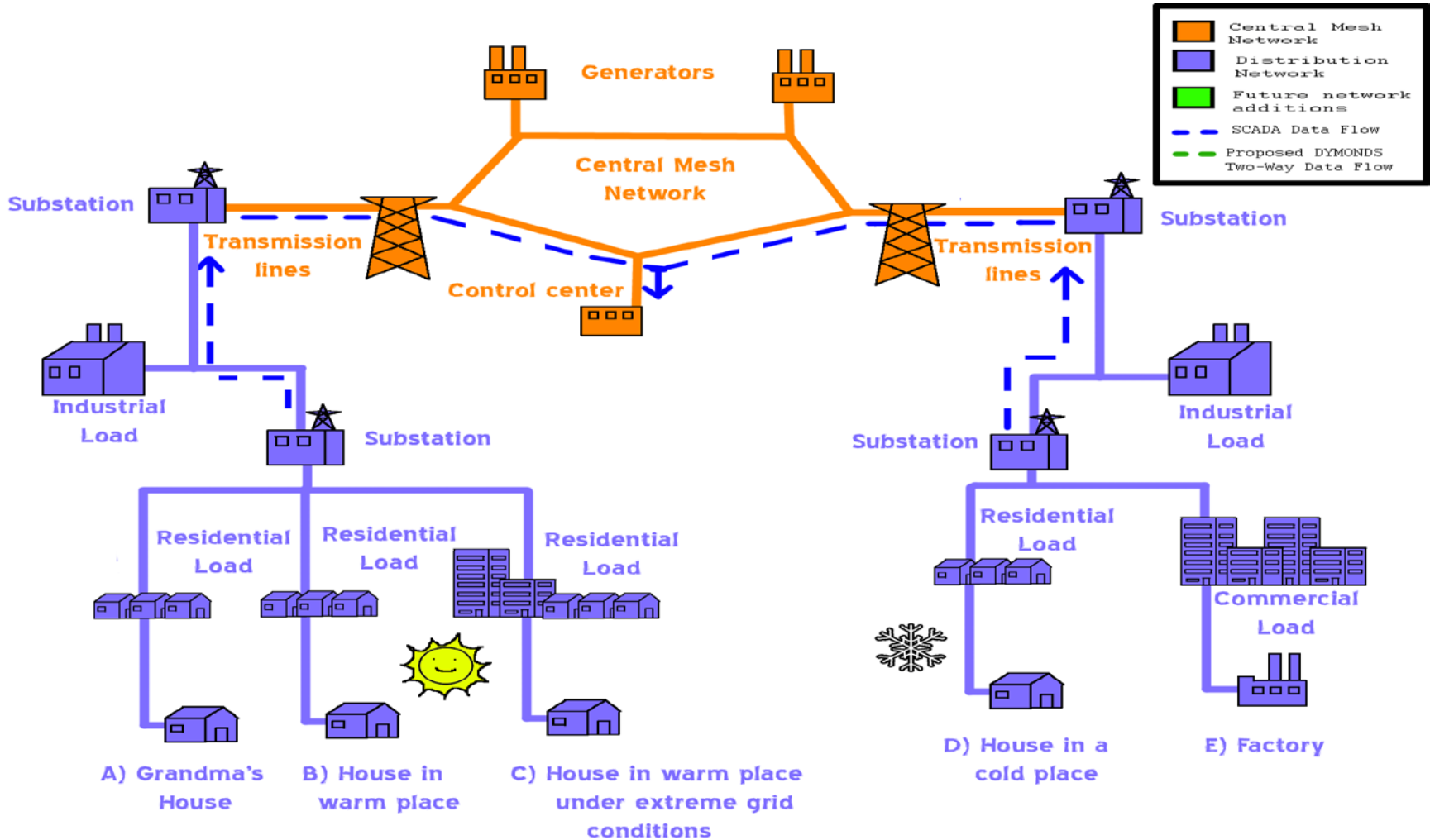

Diverse users

A) Grandma's House:
Smart Metering, Automation for Appliances

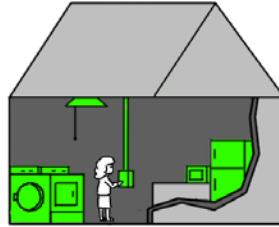

B) Sunny Place 1:
Solar Panel

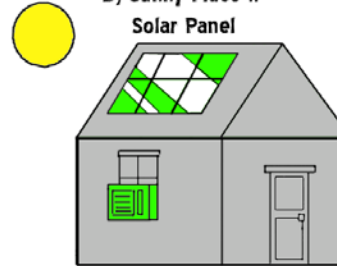

C) Sunny Place 2:
Solar Panel, Backup Power, Storage

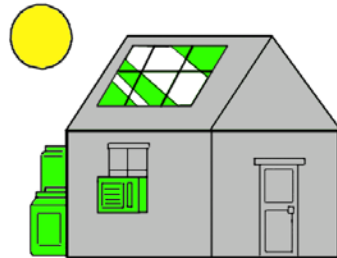

D) Cold Place:
Backup Power, Micro CHP



E) Green Factory: Automation, Proximity to Wind Farm

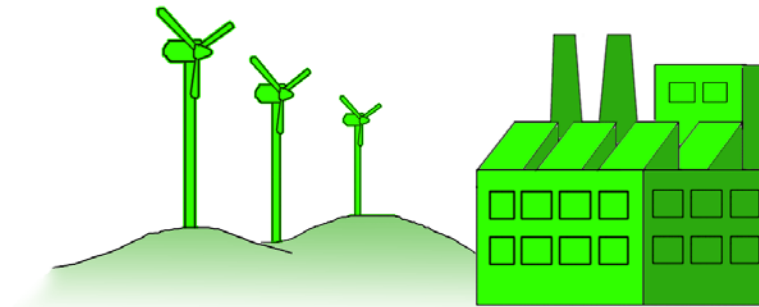

What is Changing?

- Much more action at the D level due to:
(1) responsive demand; (2) variable distributed resources (DRs); (3) new security and environmental constraints.
- Much harder to predict supply-demand (SD) imbalance accurately by the control centers without self-commitment by the DRs and LSEs (both short-term and long-term).
- Correlating diverse loads and DRs much harder than in the past (T level cannot assume D-loads known.)

Future Smart Grid (Physical system)

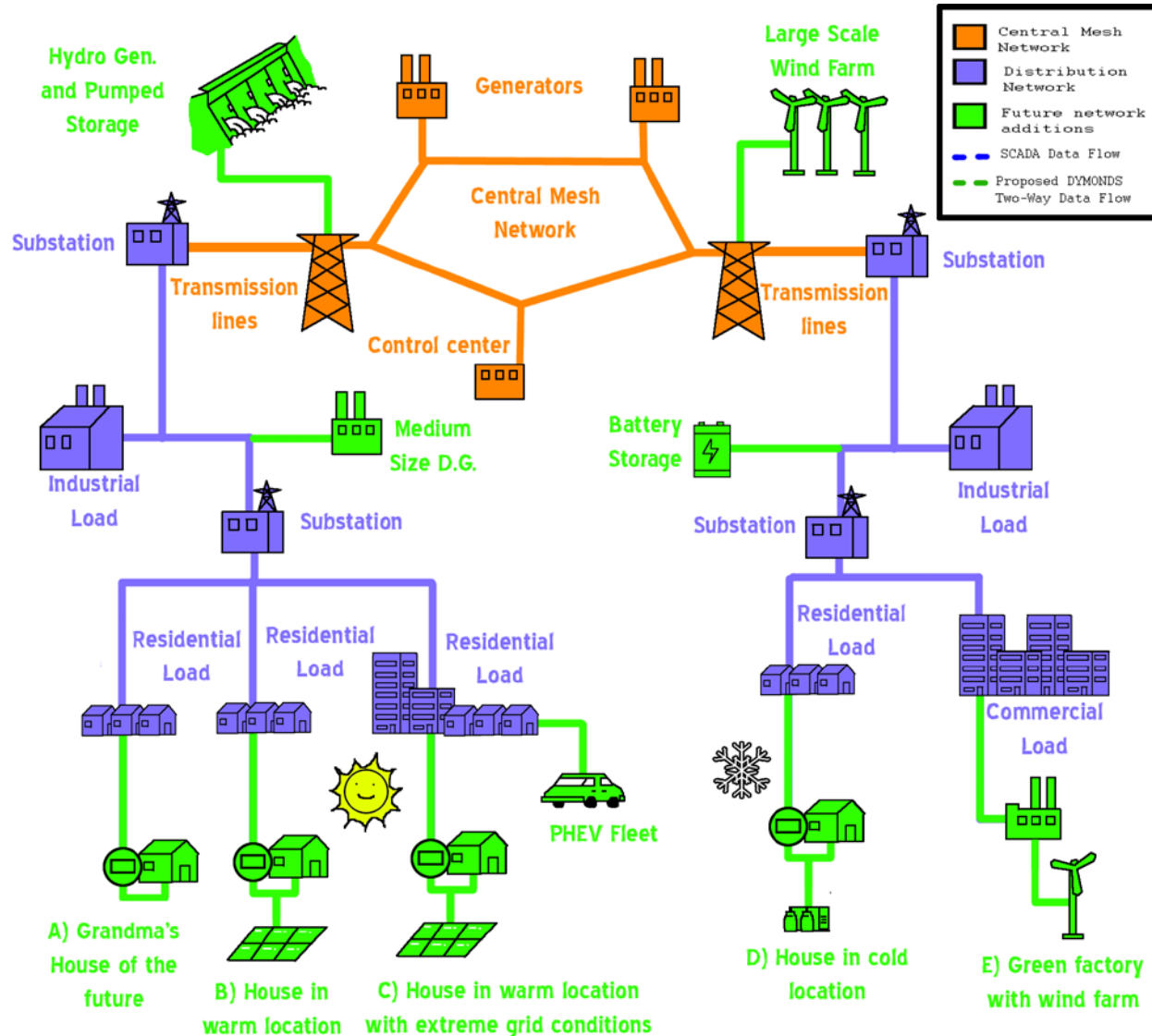

Critical: Transform SCADA

- From single top-down coordinating management to the multi-directional multi-layered interactive IT exchange.
- At CMU we call such transformed SCADA Dynamic Monitoring and Decision Systems (DYMONDS) and have formed a Center to work with industry and government on: (1) new models to define what is the type and rate of key IT exchange; (2) new decision tools for self-commitment and clearing such commitments. [\http://www.eesg.ece.cmu.edu](http://www.eesg.ece.cmu.edu).

New SCADA

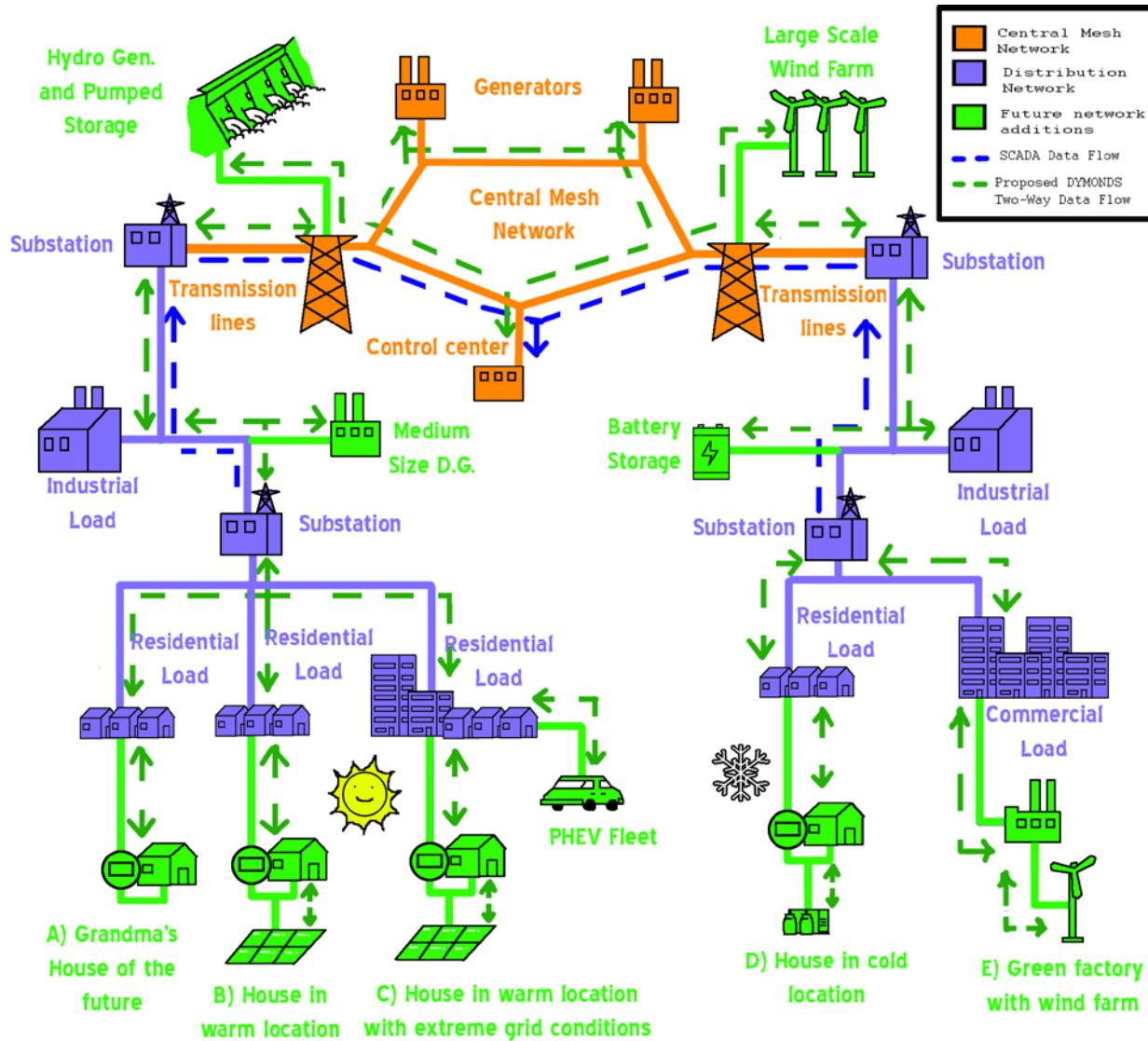

Smart users

A) Grandma's House:
Smart Metering, Automation for Appliances

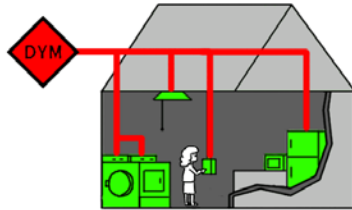

B) Sunny Place 1:
Solar Panel

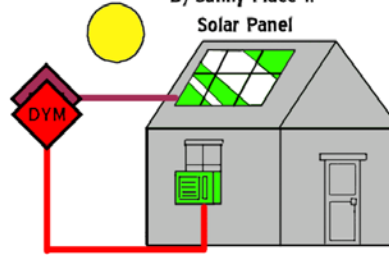

C) Sunny Place 2:
Solar Panel, Backup Power, Storage

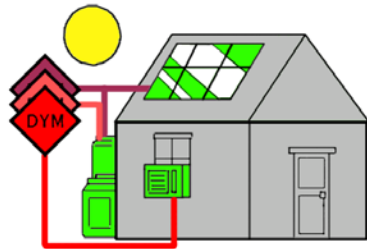

D) Cold Place:
Backup Power, Micro CHP



E) Green Factory: Automation, Proximity to Wind Farm

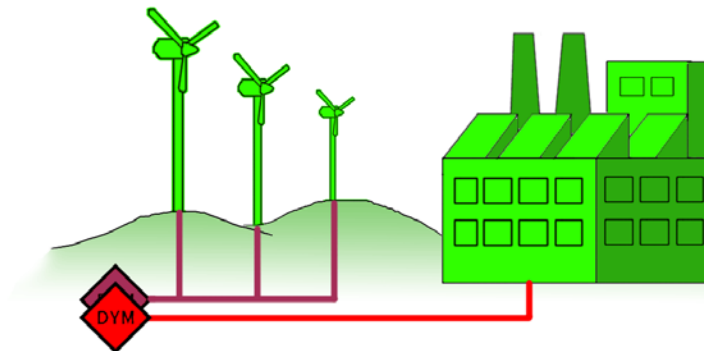

DYMONDS-enabled Physical Grid [1]

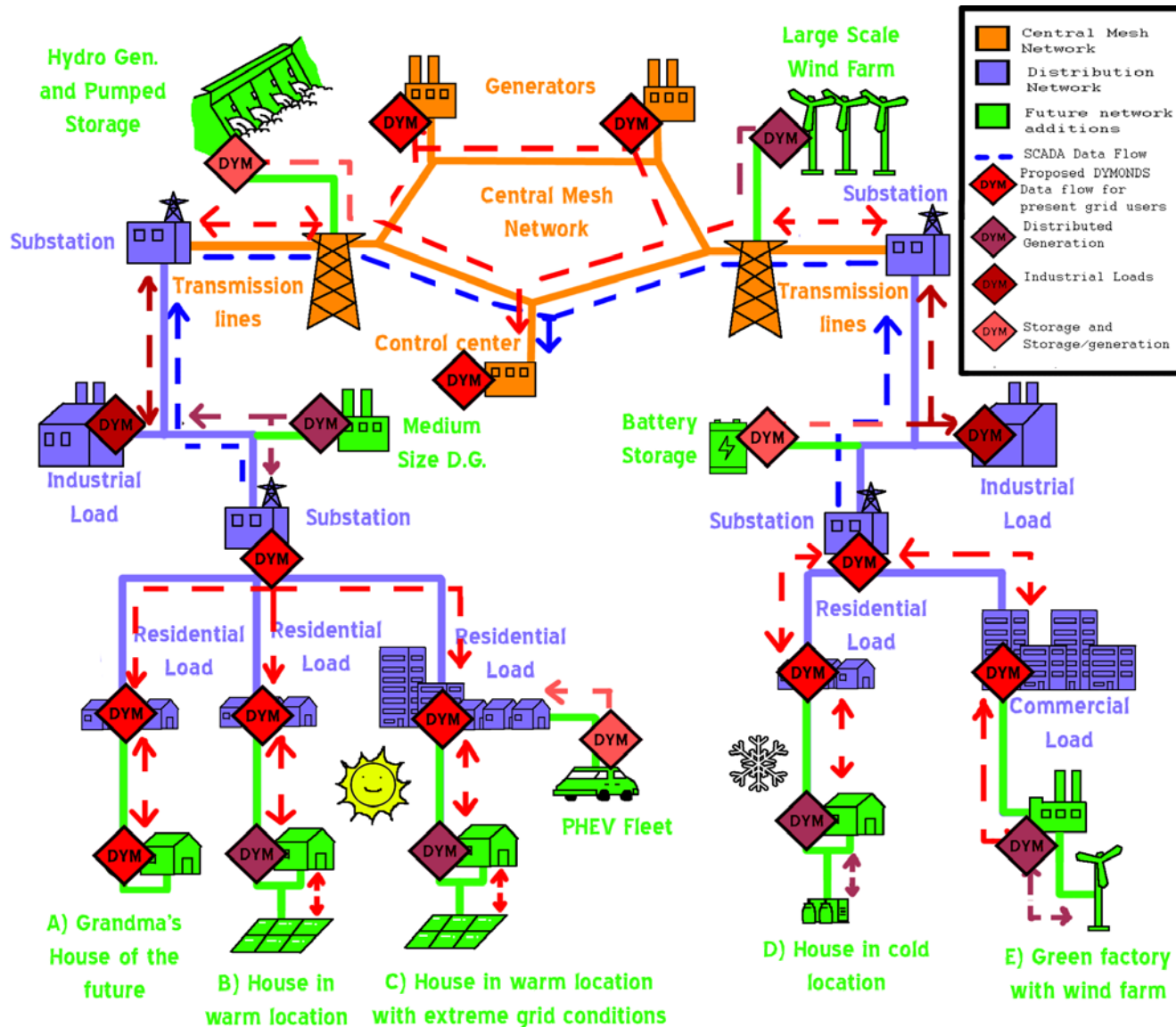

T&D as an Enabler

- New dispatch of self-committing resources will make it possible to fit different pieces of the puzzle together.
- Much more reliance on distributed sensing, actuation and coordinated management of these resources. Real time awareness of D flows.
- No models, no simulations, no decision tools. Without these, it will be much more costly to proceed. **R&D ahead of us.**

New DYMONDS Functionalities

- **Just-in-Time (JIT)** --predictions; dynamic look-ahead decision making
- **Just-in-Place (JIP)** --distributed, interactive, multi-layered
- **Just-in-Context (JIC)** ---- performance objectives function of organizational rules, rights, and responsibilities (3Rs) and system conditions.
- Sample examples of improved performance—on-going work in EESG <http://www.eesg.ece.cmu.edu>

Just-in-Context (JIC) –Need for Smart Regulation [2]

- Need to revisit the performance metrics in the changing industry (cost vs. benefits; cost allocation vs. value-based services)
- The cost of managing uncertainties –very different depending on the context
- The value of high technologies (DYMONDS) –very different depending on the context
- Heterogeneous performance metrics (reliability, short term-, long term-efficiency; environmental impacts; cyber security)
- Who takes the risks for what and at which price?

Wind prediction, look-ahead management using storage (Xie,2009)

Table 1: Generator parameters of the 12-bus system

Generator ID	Type	Min Generation	Max Generation	Generation Cost	Ramp Rate
1	Gas	20	500MW	350\$/MWh	150MW/5 min
2	Coal	20	500MW	150\$/MWh	15MW/ 5min
3	Wind	0	250MW	0\$/MWh	150MW/5 min
4	PV	0	600MW	0\$/MWh	200MW/5 min
5	Coal	10	500MW	100\$/MWh	10MW/5 min

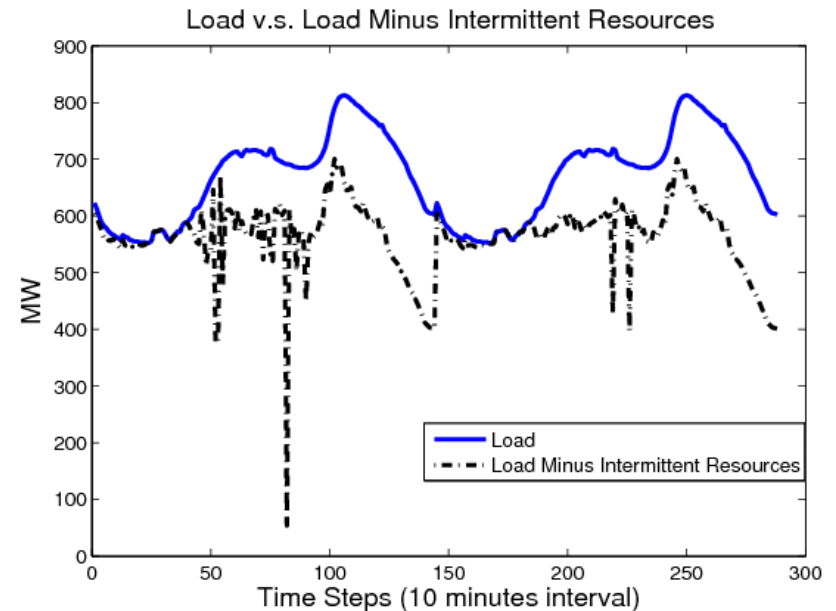
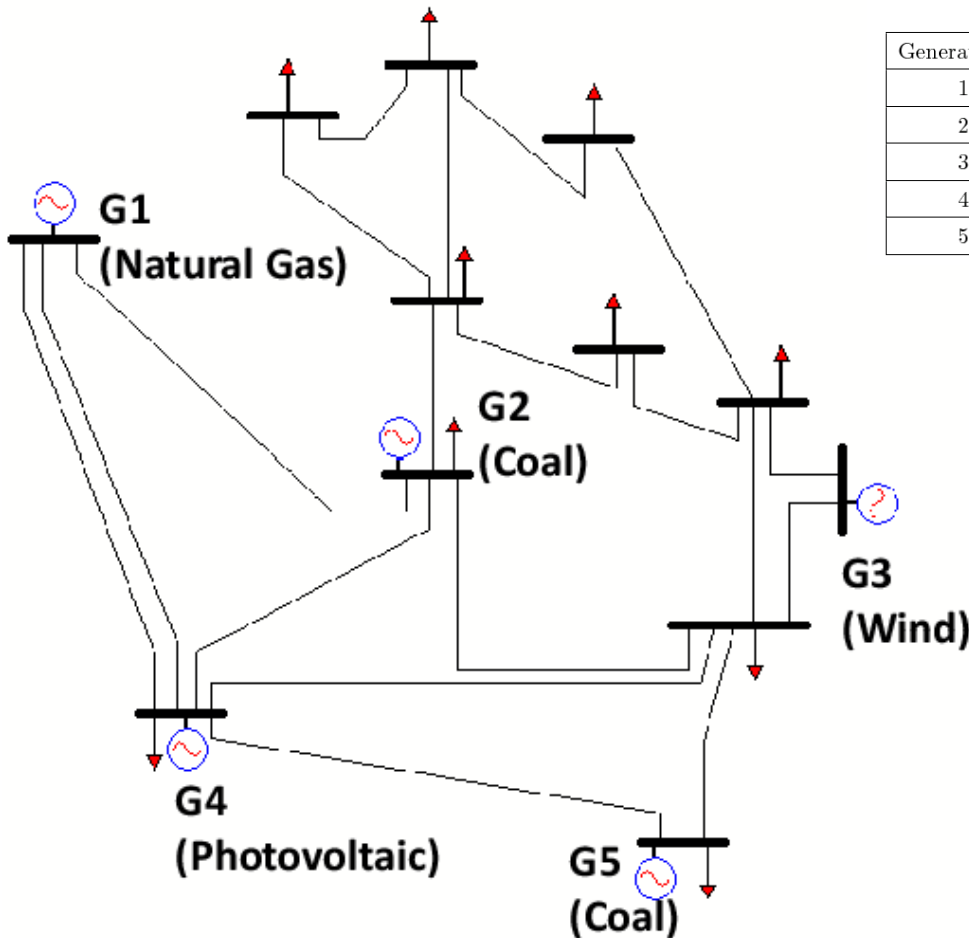

Compare the outcome of ED from both the centralized and distributed MPC approaches.

Coal Unit 2 (Expensive) Generation

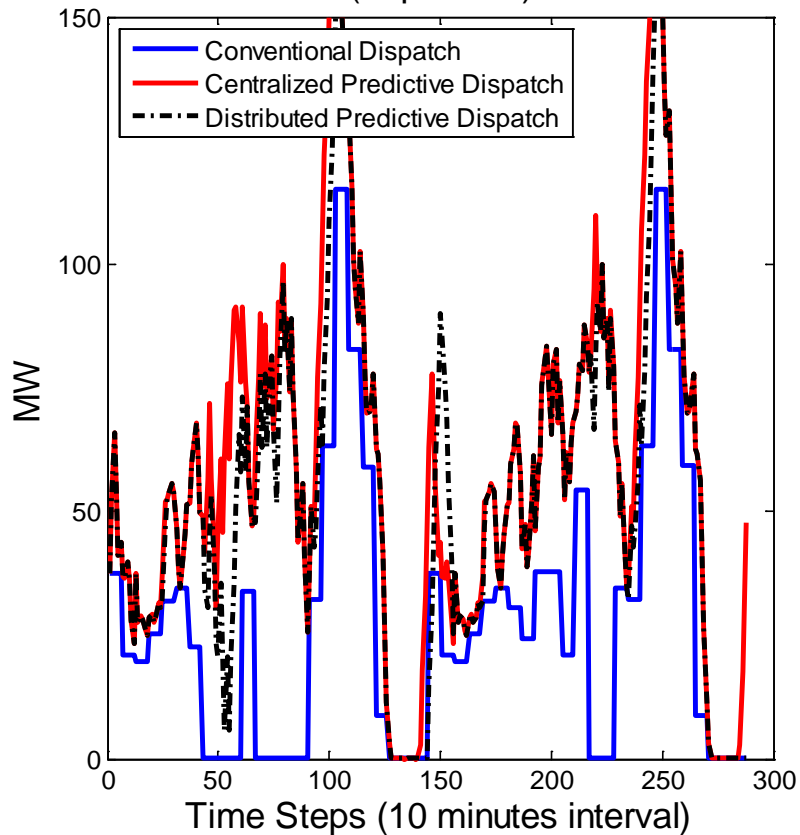

Coal Unit 2 Generation: Zoomed In

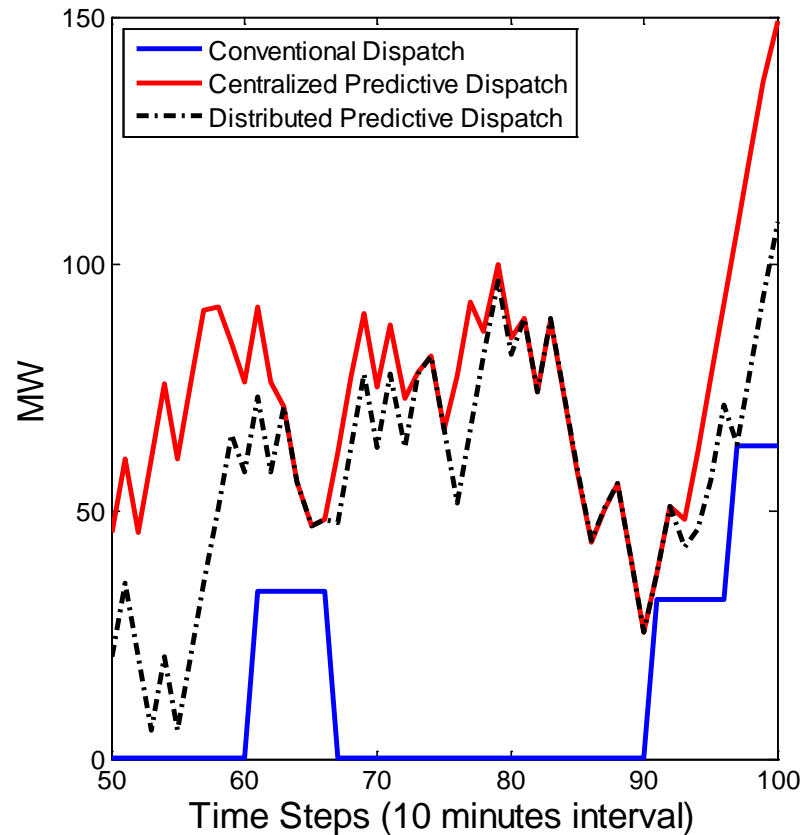

BOTH EFFICIENCY AND RELIABILITY MET

Adaptive Load Management (Joo, 2009)

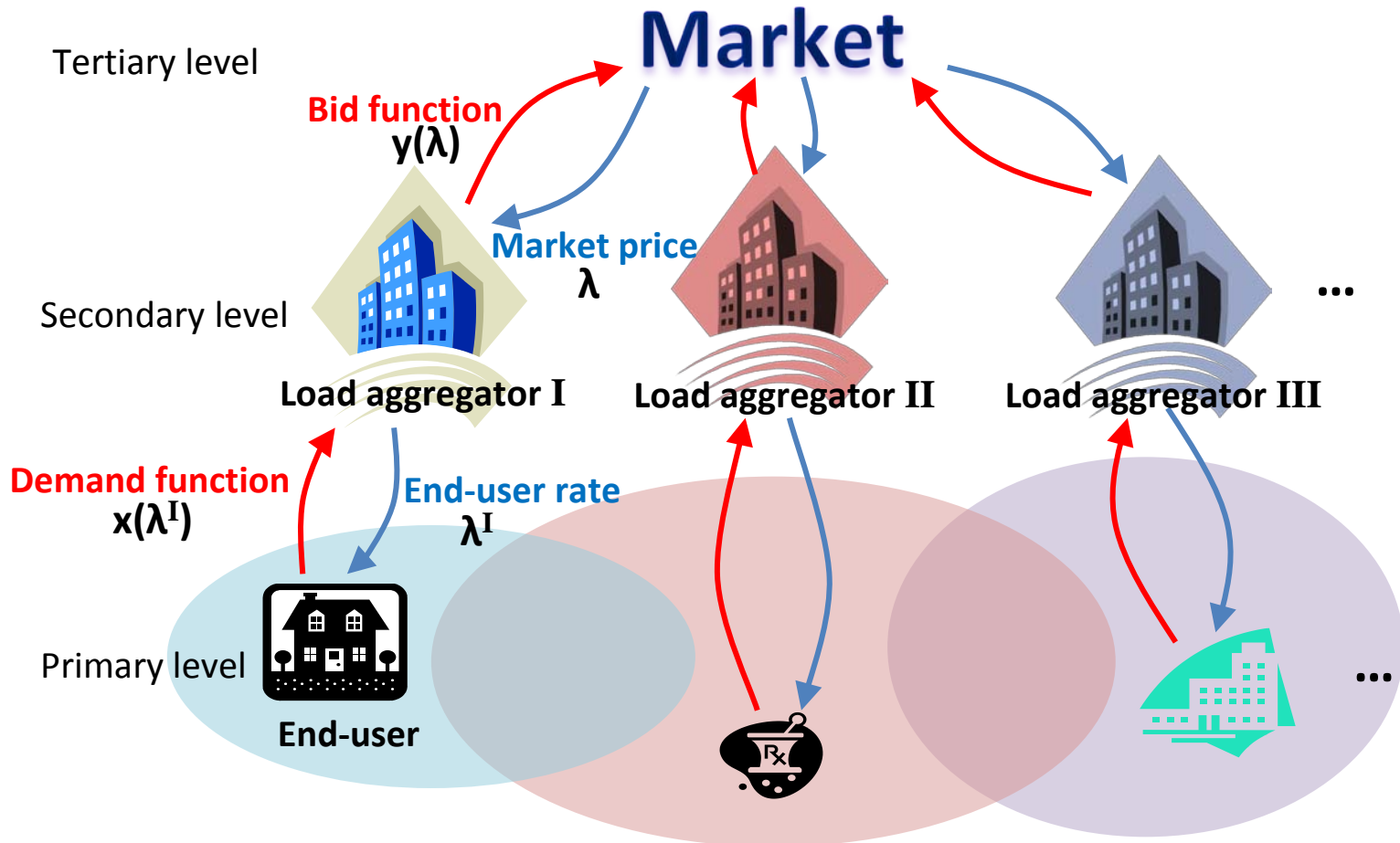

Optimal Control of Plug-in-Electric Vehicles: Fast vs. Smart (Rotering,2009)

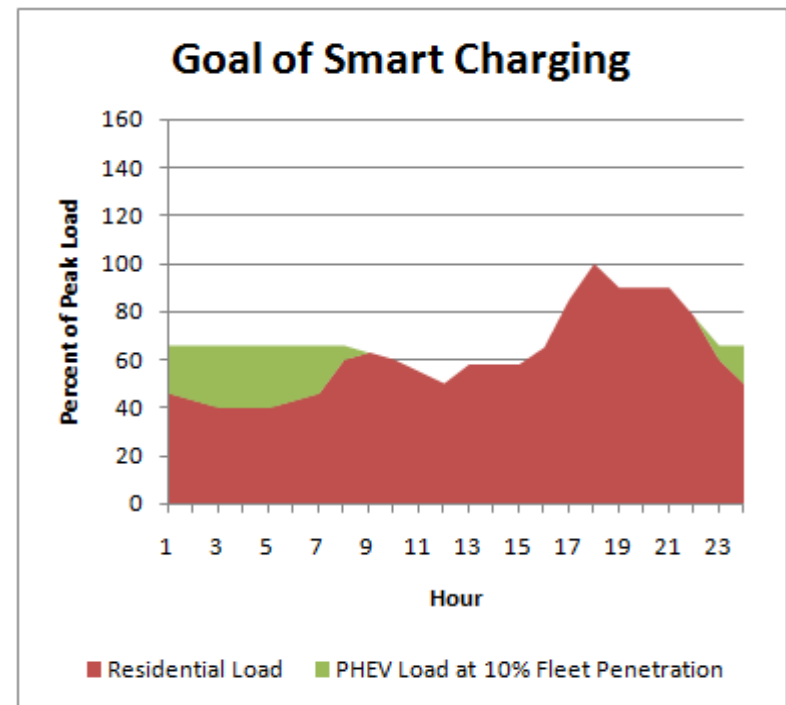
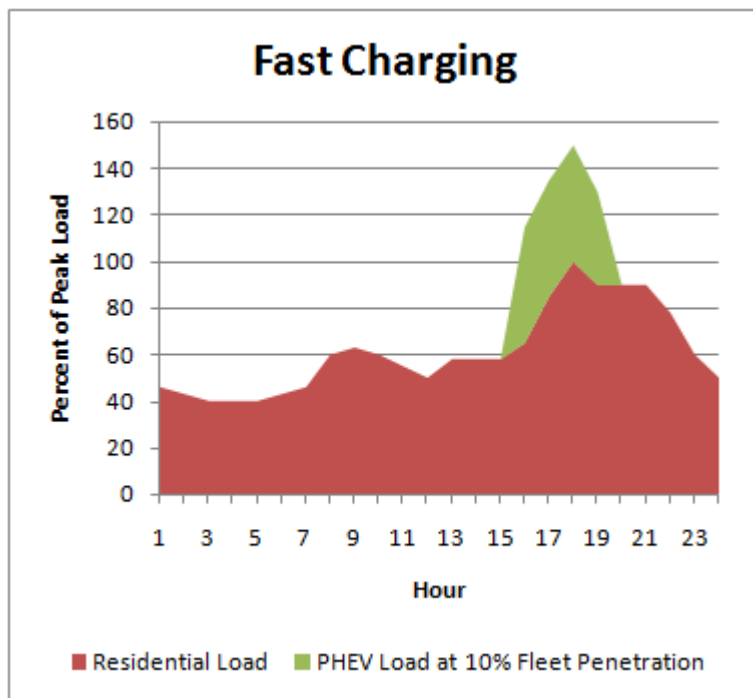

Information flow—Fantastic Use of Multi-layered Dynamic Programming

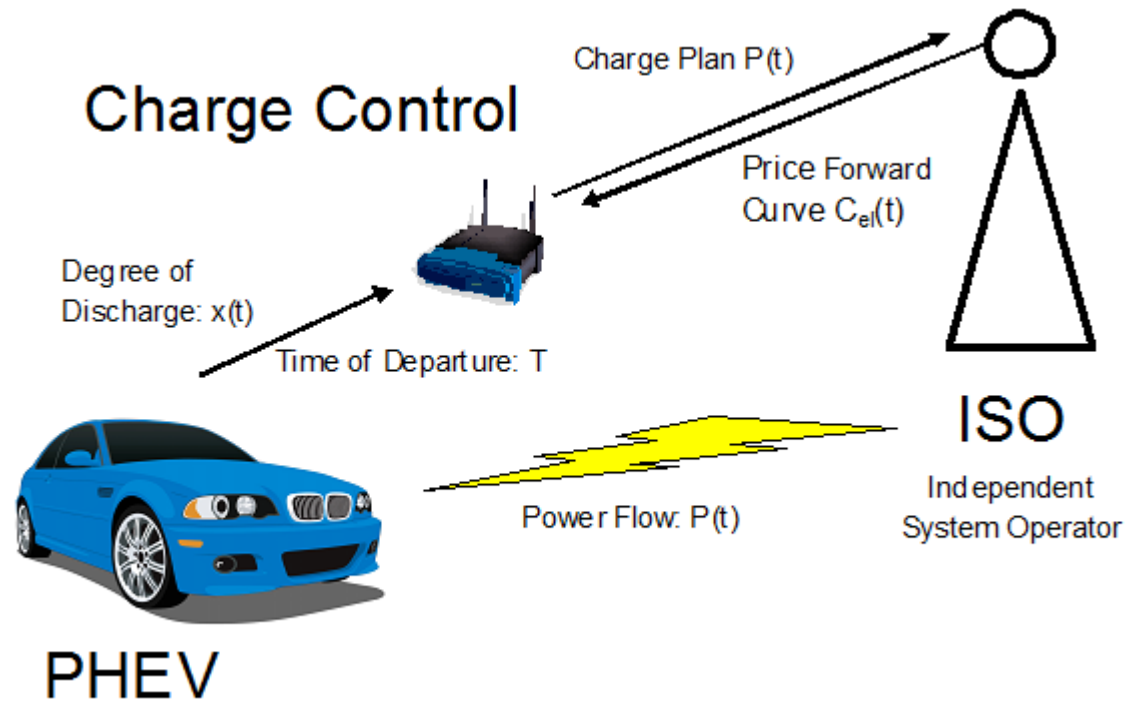

Integrating >50% Wind [2]

MPC-based DYMONDS Dispatch with 50% Wind

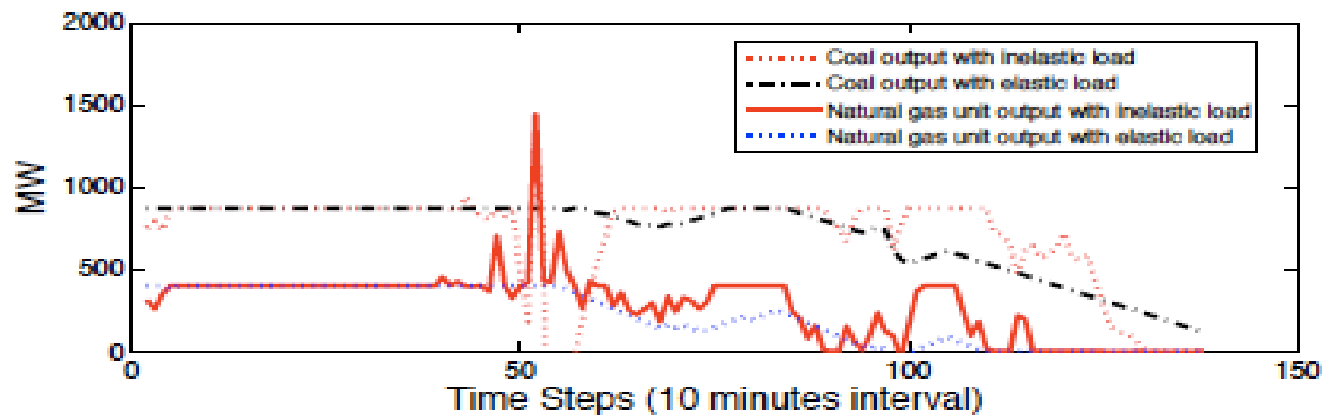
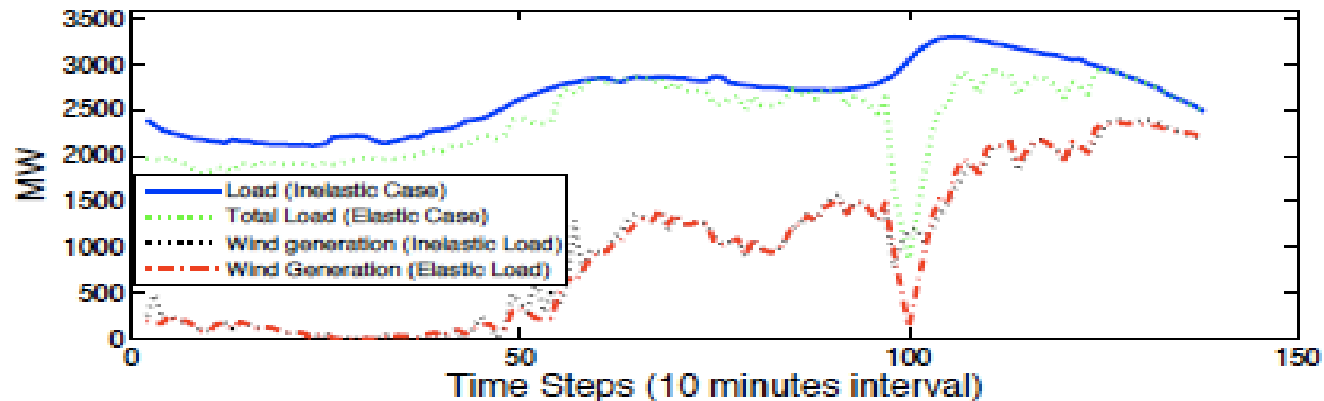

Potential Savings with Self - Committing Dispatch

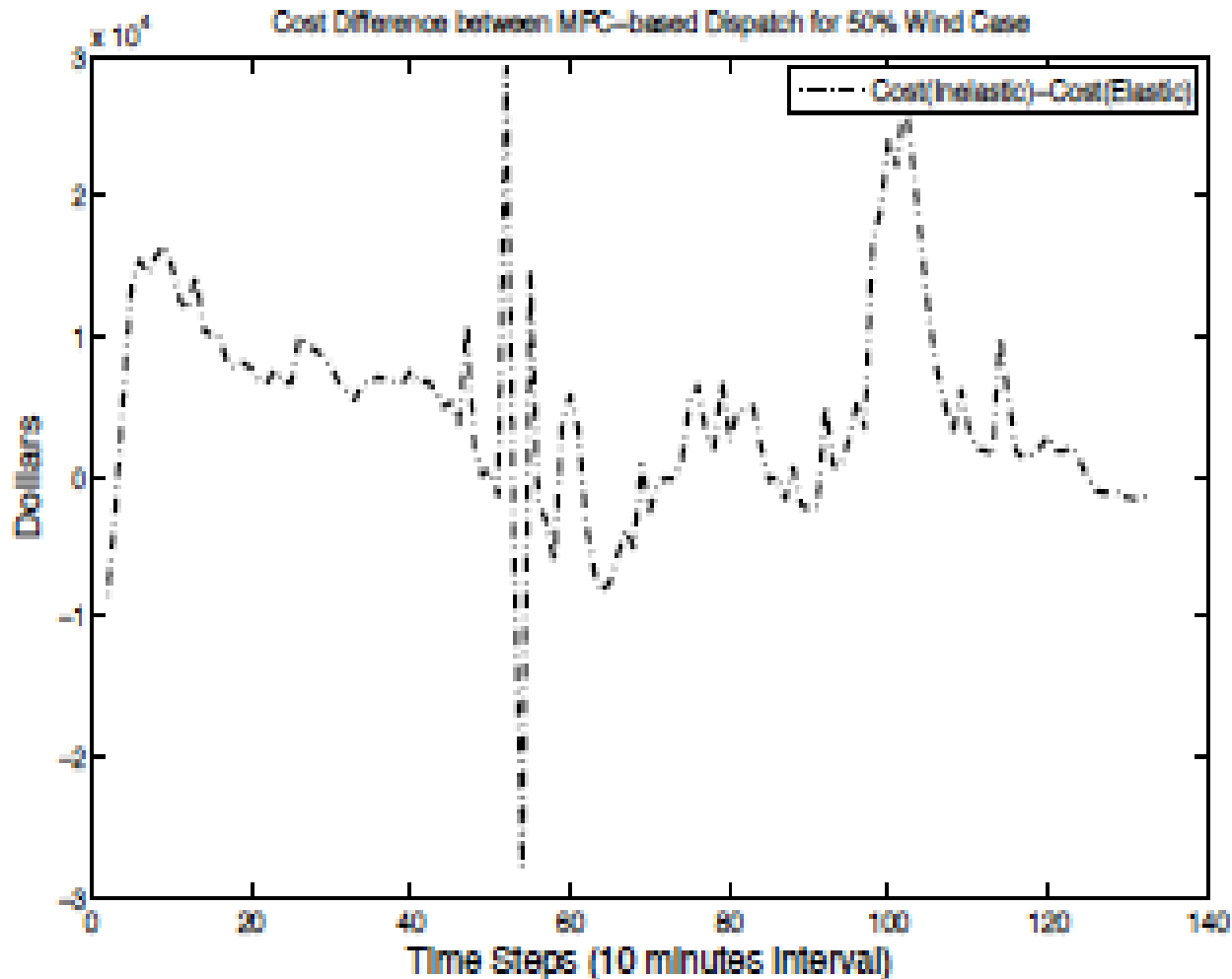

ALM not Direct Load Control [Joo]

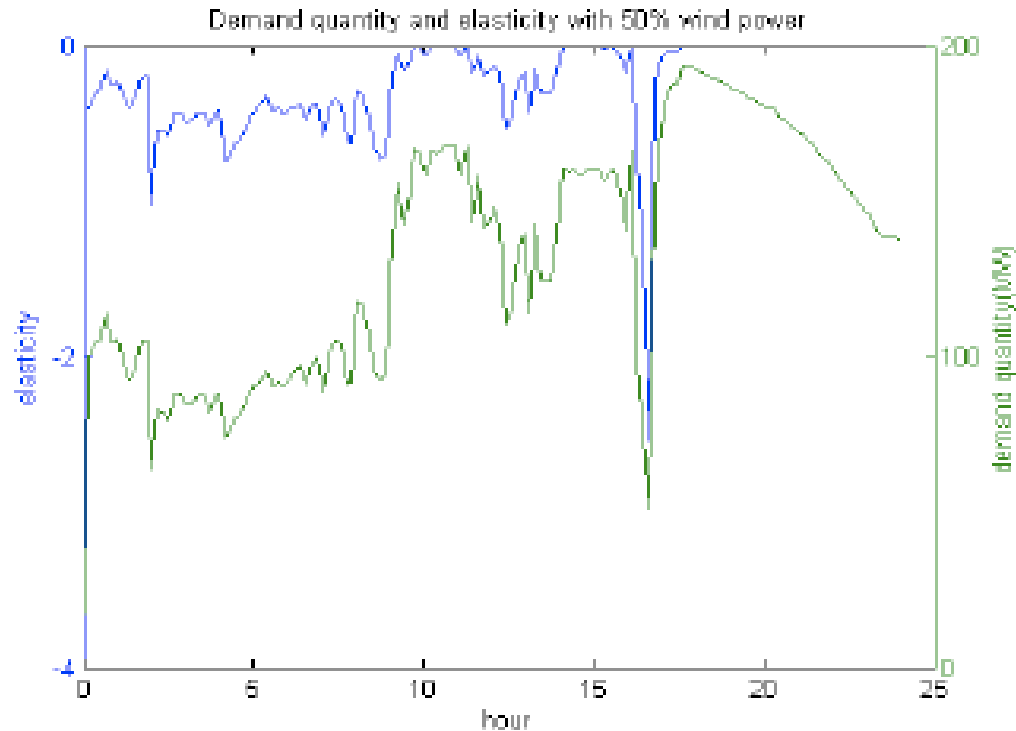

Fig. 24. Price elasticity of demand and demand quantity(MW) with 50% wind penetration

Electric Energy Systems Group (EESG)

<http://www.eesg.ece.cmu.edu>

- A multi-disciplinary group of researchers from across Carnegie Mellon with common interest in electric energy.
- Truly integrated education and research
- Interests range across technical, policy, sensing, communications, computing and much more; emphasis on systems aspects of the changing industry, model-based simulations and decision making/control for predictable performance.

References

- [1] Ilic, Marija “Dynamic Monitoring and Decision Systems (DYMONDS) and Smart Grids: One and the Same, CMU EESG WP 019, October 2009.
- [2] Ilic, Marija “IT-enabled Rules, Right and Responsibilities (3Rs) for Efficient Integration of Wind and Demand Side Response”, Public Utility Fortnightly Magazine, Dec 2009.
- [Joo,2009] of J.Y. Joo and M, Ilić, “A Multi-Layered Adaptive Load Management (ALM) System: Information exchange between market participants for efficient and reliable energy use” Electric Energy Systems Group Working Paper R-WP17, Carnegie Mellon University, 2009.
- [Xie, 2009] Marija Ilic, Le Xie, and Jhi-Young Joo, “Dynamic Monitoring and Decision Systems (DYMONDS) for Efficient Integration Wind Power and Price-Responsive Demand: Proof of Concept on the IEEE RTS System”, EESG WP 2009.
- [Rottering, 2009] Nik Rottering, CMU ECE and ETH Master thesis, 2009.