



Building the Smart Grid – Deployment Activities

Gary Stuebing
Systems Integration Manager
September 16, 2009



FACTS ABOUT DUKE ENERGY

- 150+ years of service
- 4 million customers
- Fortune 500
- \$50 billion in assets
- Stock dividends for 80+ years
- Traded on NYSE as DUK
- Dow Jones Sustainability Index





OUR ASPIRATIONS

- Decarbonize our power generation
- Help make our communities the most energy efficient in the world

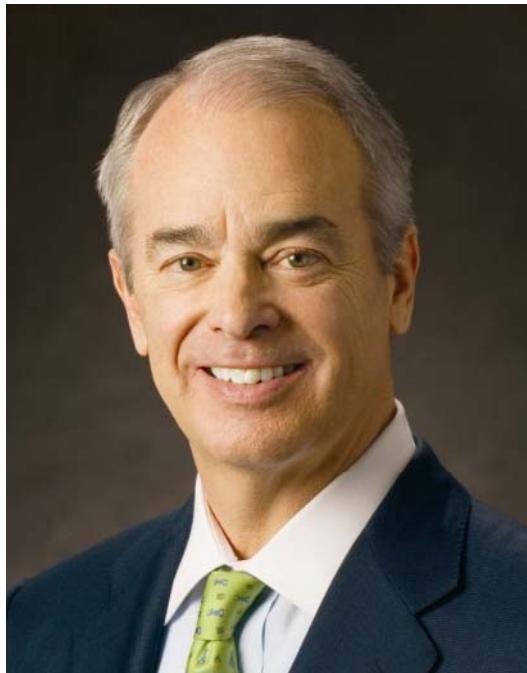

"These aspirations are grounded in our commitments to provide our customers with clean, affordable and reliable electric and gas services."

Jim Rogers

Chairman, President and CEO



HOW WE WILL ACHIEVE OUR ASPIRATIONS

- Build new, more efficient generation and retire older, coal-fired units
- Modernize our grid by replacing less efficient analog technology with advanced digital technology
- Make energy efficiency the “fifth fuel” by implementing our save-a-watt model in each of our jurisdictions



CLIFFSIDE PLANT
CONSTRUCTION



INTELLIGENT
SWITCH



WATER HEATER
BLANKET



U.S. FRANCHISED ELECTRIC AND GAS

- 5 states: North Carolina, South Carolina, Indiana, Ohio and Kentucky
- 47,000 square miles of service area
- 28,000 MW of regulated generating capacity
- 4.0 million retail electric customers
- 500,000 retail gas customers

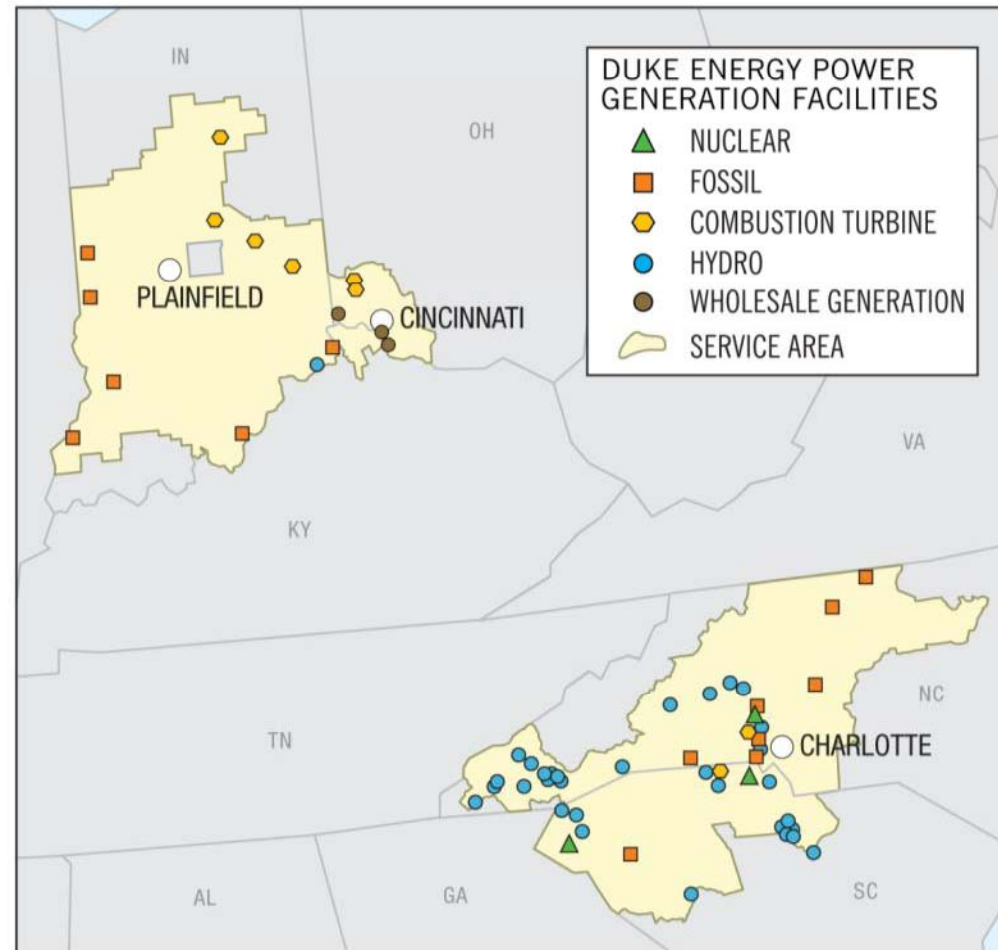



General Smart Grid Architecture

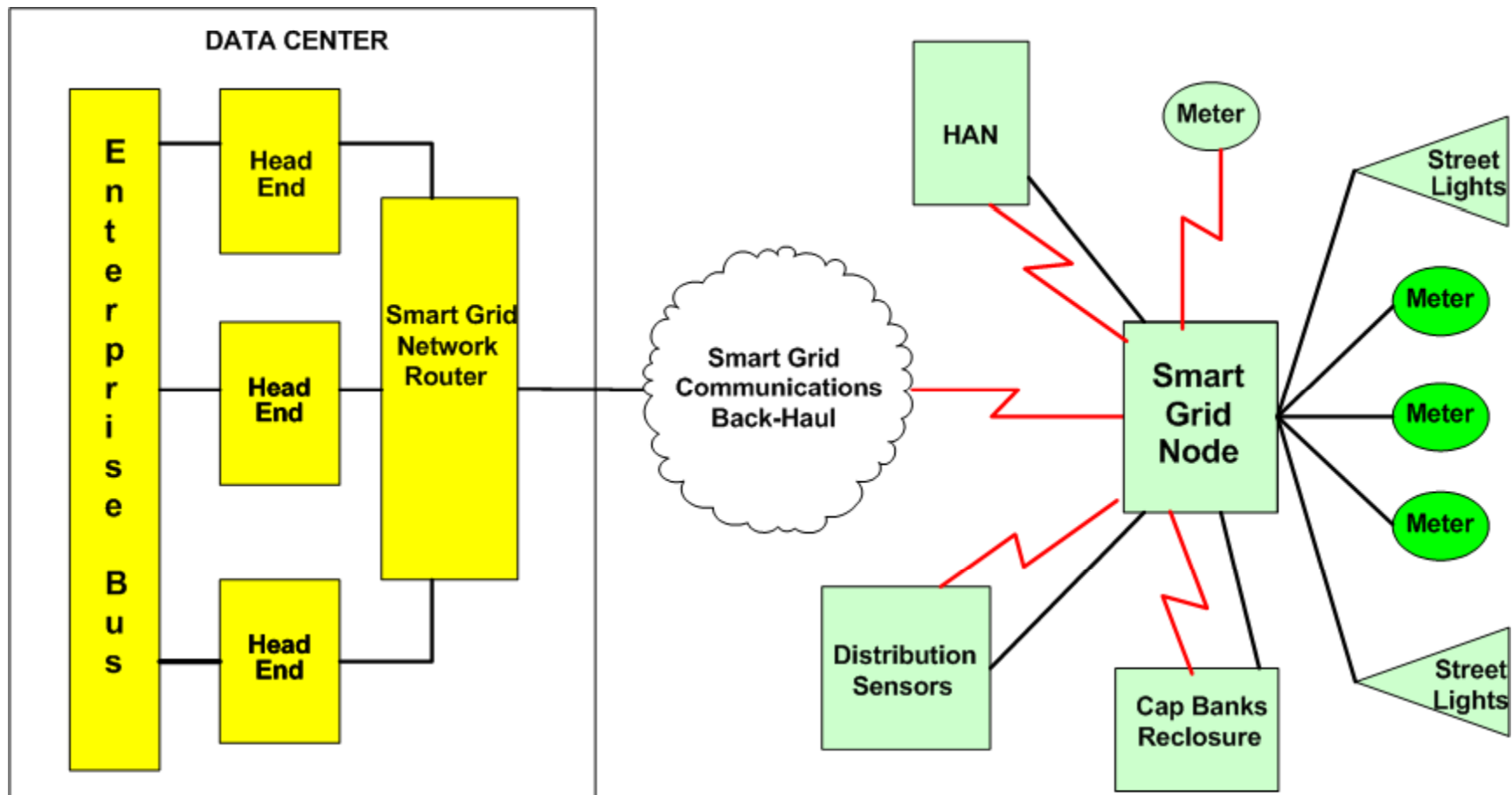



Basic Requirements

- Support will be required for a wide variety of networks and devices in a Smart Grid Implementation.
- A common set of protocols is needed to provide interoperability across a network containing wide variances in topology and bandwidth.
- Proven technology will be required for Smart Grid implementations.
- A secure Transport Layer function is a requirement.
- Non-proprietary



Reflecting on 2009

In Ohio

- Installed 60,000 smart electric meters, 36,000 smart gas meters, 4,000 communication nodes
- Piloting customer payment options, customer daily energy usage information

Carolinas

- Installed 21,500 smart electric meters
- Installed 213 solar panels and storage battery at substation
- Piloting REMS (Residential Energy Management System)



More on 2009

- Installed three self-healing units in Ohio and one in North Carolina
 - Distribution devices to detect outage, identify fault and re-route power automatically
- Received \$200 million in Smart grid federal stimulus funds
- Launched the Duke Energy Smart Grid page
 - <http://www.duke-energy.com/about-us/smart-grid.asp>



In 2010...

- Installation of another 80,000 smart electric meters, 60,000 smart gas meters, 10,000 communication nodes in Ohio
- Submission of a new plan to the Indiana Regulatory Commission
 - Original Smart Grid proposal was rejected last year
- Partnering with the Public Utility Commission of Ohio (PUCO), Ohio Partners for Affordable Energy, Kroger Company and Office of Ohio Consumers' Counsel
 - Collaboration on pricing, billing and enabling technologies in customer service
- Working to address stipulations on stimulus funds with DOE
- Installation of an additional self healing units in Ohio on Distribution system.



...2010

- Working to launch the next generation billing and customer management system. The Enterprise Customer System (ECS) will support advanced Smart Grid technologies as well as provide a base for new products and services
- We will continue to pilot customer programs and introduce some projects on a larger scale as existing pilots conclude
- Hosting the Smart Grid Road Show in Cincinnati. May 11-12
 - <http://www.smartgridroadshow.com>