



An Advanced Power Processor
For Utility Grid Infrastructure

January 20, 2010

Dr. Simon Bird
simon_bird@siliconpower.com

Advanced Power Processors

- Utility Grid Infrastructure Challenges
- Why Use an Advanced Power Processor?
- Advanced Power Processor Features
- Advanced Power Processor Applications
 - Transfer Switches
 - Current Limiters
- Summary

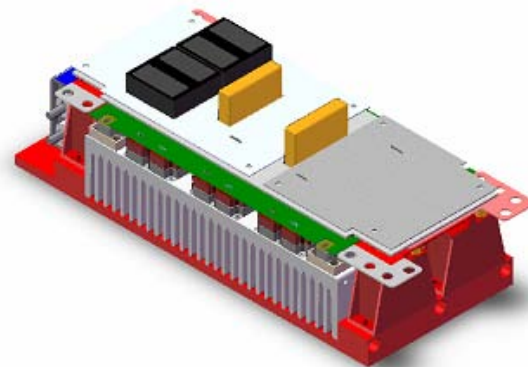

Utility Grid Infrastructure Challenges

- Load growth
- Power quality
- Renewable energy integration
- Response to fault events
- Grid security and communications
- Aging legacy/electro-magnetic infrastructure
- Operational and maintenance costs



Why use an Advanced Power Processor?

- Our energy infrastructure needs technologies that provide:
 - Higher efficiency, faster speed systems for power flow control – not just switches
 - Higher power density
 - Reliability
 - Automation and active communication
- Needs to be applicable across all sectors of grid, including all T&D applications

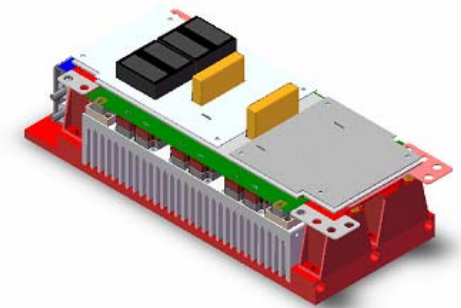

Advanced Power Processor Features

- Advanced Power Processor: a versatile and scalable device that integrates power chips, thermal management and control software in a compact and affordable package
- Converts electrical power from one form to another
- Conforms to industry standards
- Affordable and scalable
- Robust
- Multiple functionality

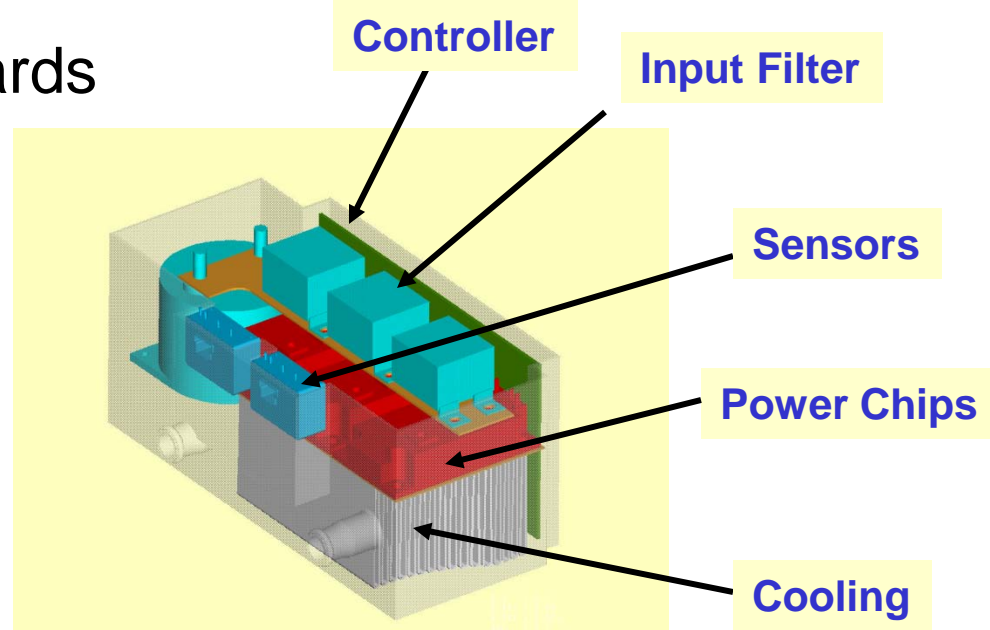

SGTO-based Power Processor Details

- Modular, standardized design, scalable across range of T&D applications
- Power Processor block with embedded high-efficiency, high-speed, high power density solid state devices
- Block includes thermal management system, built-in controls and diagnostics
- Standard block rated at 5kV, 600A
- Compact: 22" x 9" x 7", 60 lbs

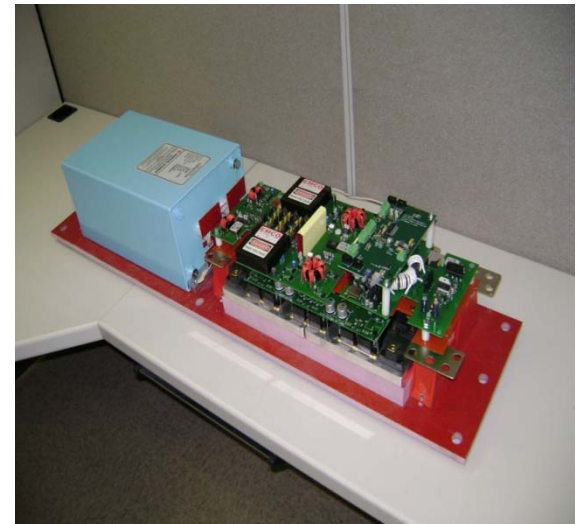

Reliability and High Power Density

- Utilize SGTO power-electronics devices for high-speed, compact assemblies
- SGTO brings 10x speed, half the losses of legacy devices
- Packaging improves reliability, junction temperature $> 125^{\circ}\text{C}$

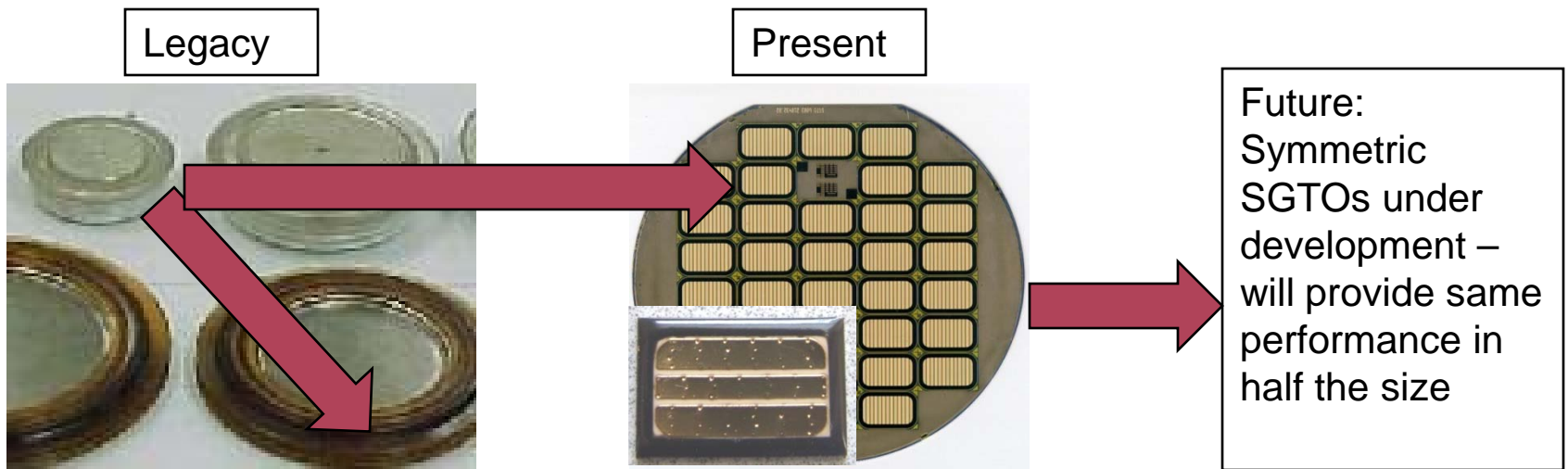

Advanced Power Processor Applications

- Transfer Switches
 - Replace traditional electro-mechanical switches
 - Allow for seamless renewable energy integration
- Current Limiters
 - Provide mechanism to respond to load growth

Transfer Switch Application

- Go beyond mere switching
- Rapid load transfer: switching time = 100 μ s
- Transfer all three phases simultaneously
- Transfers independent of phase angle

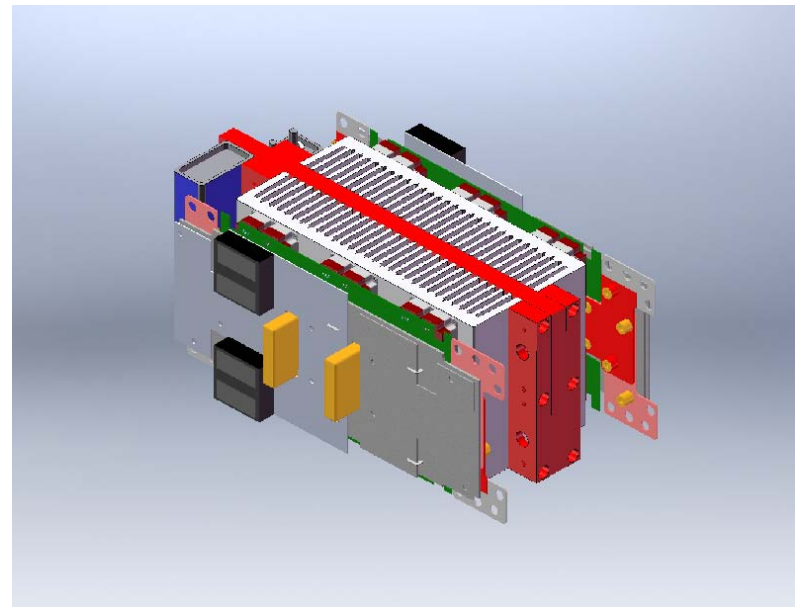
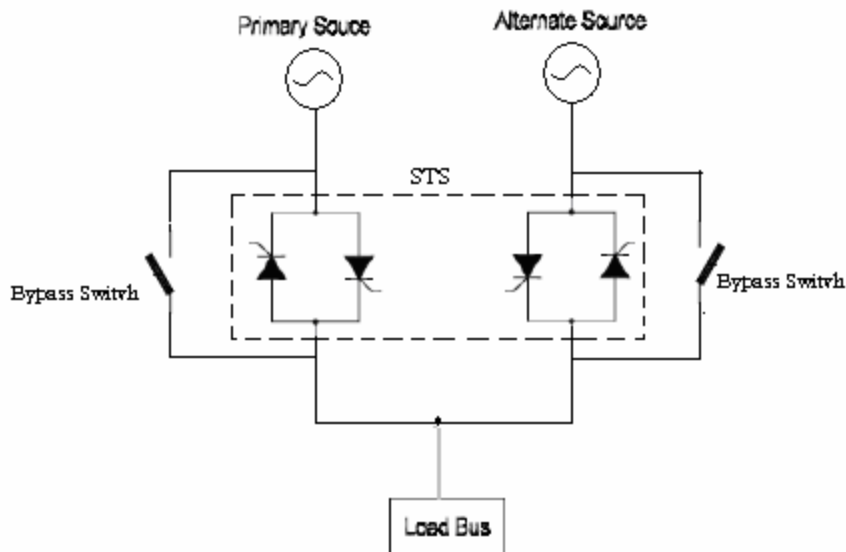

Transfer Switch Overview

- 15kV, 600A system:
60" (h) x 40" (w) x 28" (d)
- Forced air cooling
- 1/3 the volume of thyristor based units
- Remote communications interface
- Boost grid security, integrity

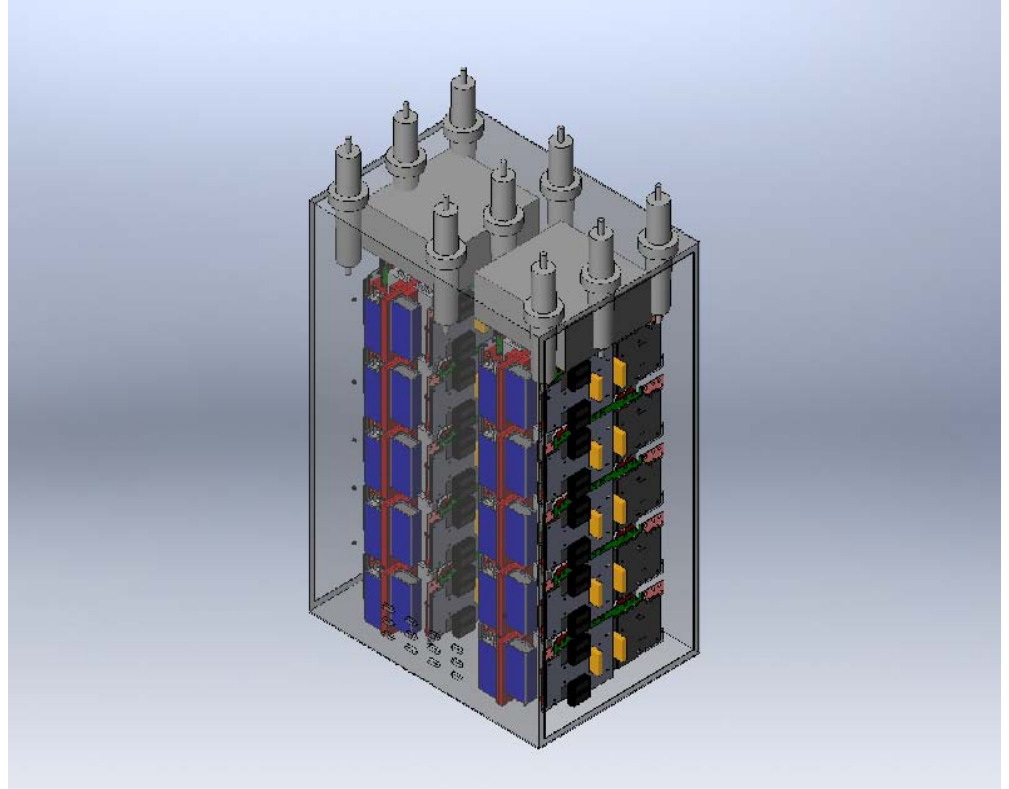

Current Limiter Application

- As load grows, available fault current increases
- Either upgrade protection schemes or limit fault current
- Current Limiters can dynamically insert additional impedance in event of fault

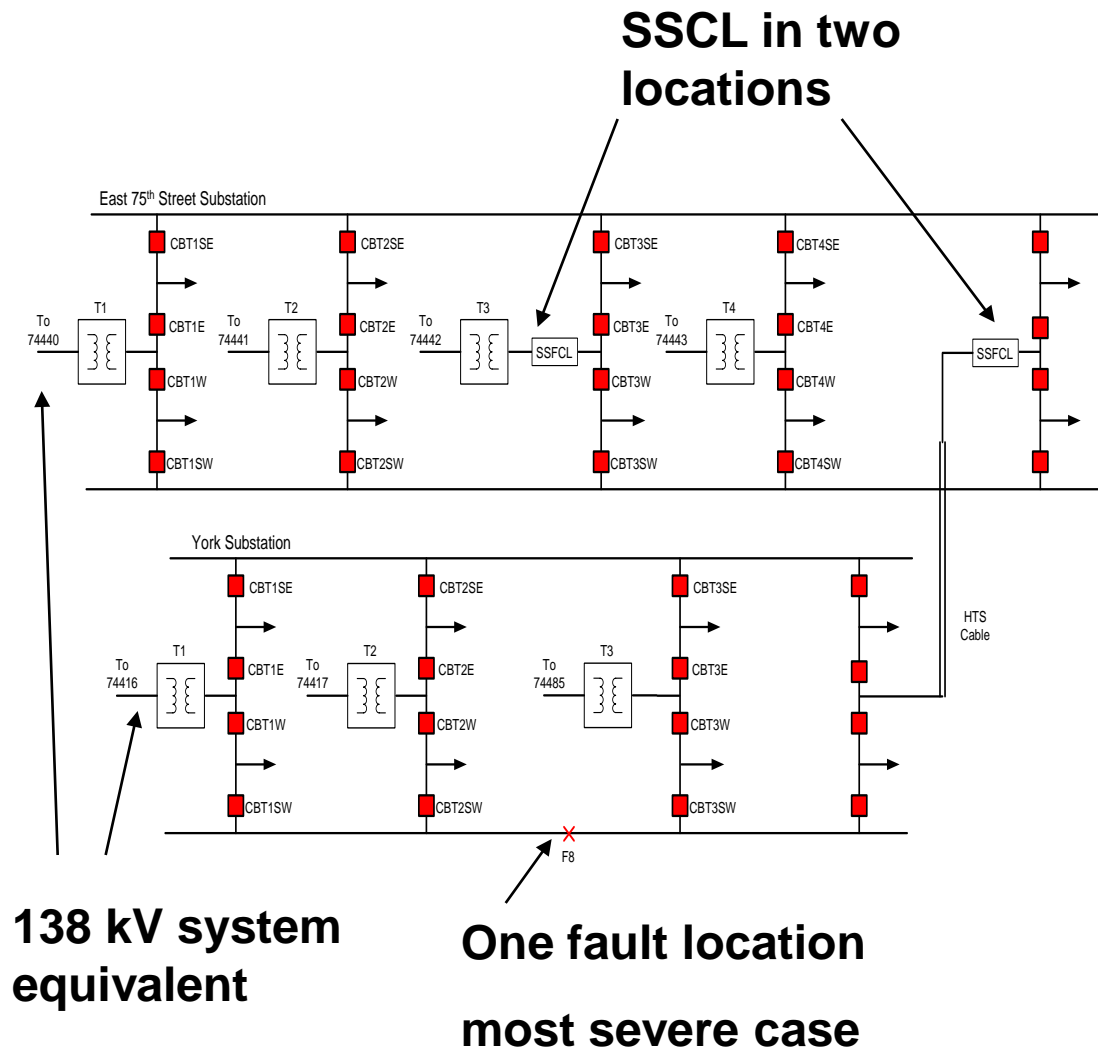

Current Limiter Operation

- Real time response to fault current events (in about 4 μs)
- Divert current to high impedance path in about 30 μs
- Current continues to flow for 30 cycles, allowing downstream breakers to trip.
- Real time monitoring and diagnostics
- Local and remote operator interfaces

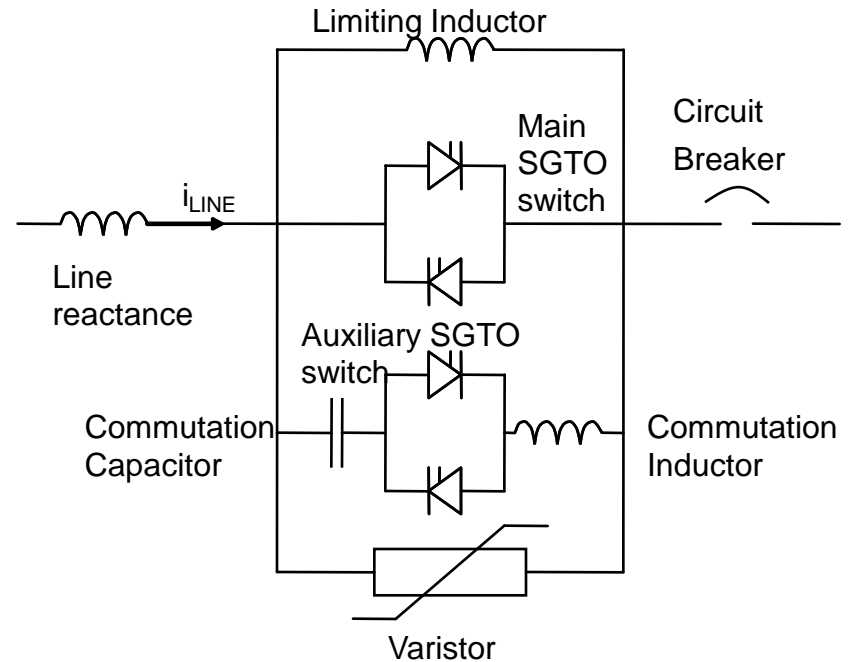

Current Limiter Application

- SGTO-based Power Processor embedded in Current Limiter:

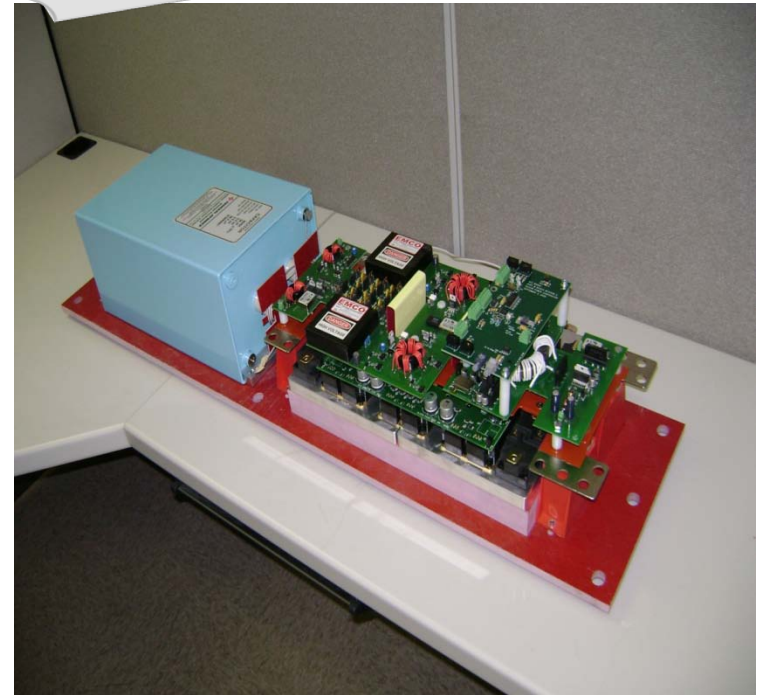
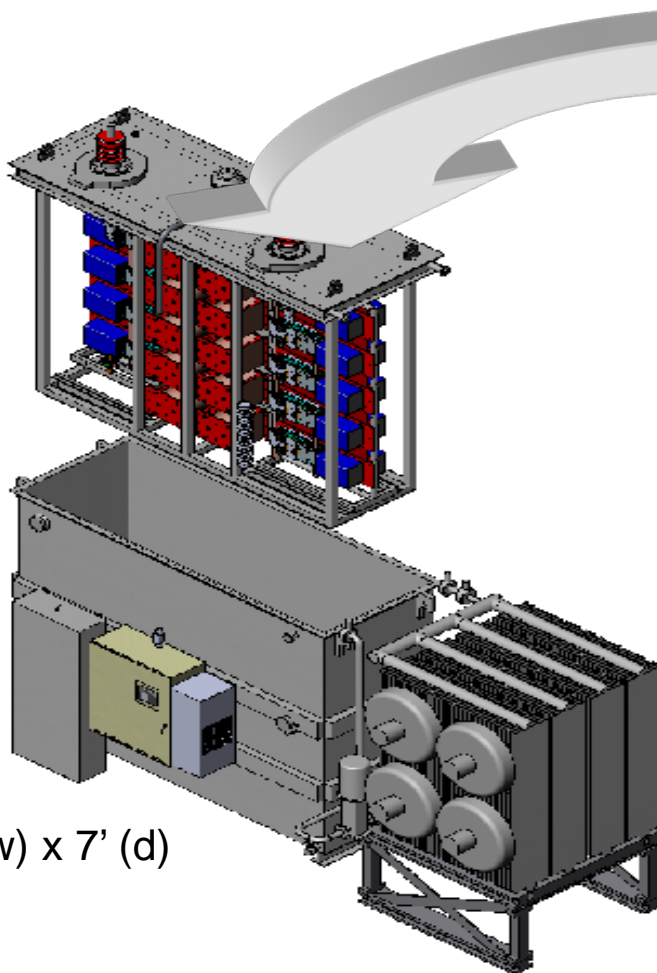

12' (h) x 22' (w) x 7' (d)

36,000 lbs

Advanced Power Processor Summary

- Applications in Transmission and Distribution infrastructure, defense and transportation environments
- Delivers enhanced efficiency, greater load capacity, higher power density, higher speed, higher reliability, power flow control
- Mitigates several limitations and challenges faced by present system
 - Fault currents
 - Distributed generation



Questions?



Dr. Simon Bird, Silicon Power Corporation
simon_bird@siliconpower.com / www.siliconpower.com