

ILLINOIS INSTITUTE
OF TECHNOLOGY

Transforming Lives. Inventing the Future.

A Perfect Power Demonstration System

Abiodun Iwayemi, Peizhong Yi, Peng Liu , Chi Zhou

*Department of Electrical and Computer Engineering
Illinois Institute of Technology
Chicago, Illinois*

*IEEE PES Conference on Innovative Smart Grid
Technologies*

19th January, 2010

A Perfect Power Demonstration System

- *Abiodun Iwayemi, Peizhong Yi, Peng Liu, Chi Zhou*

Contents

- Introduction
- The IIT Perfect Power Project
- The Zigbee Protocol
- The Perfect Power System Test Bed
- Demonstration Modes
- Conclusion

A Perfect Power Demonstration System

- *Abiodun Iwayemi, Peizhong Yi, Peng Liu, Chi Zhou*

Introduction – The Problem

Energy efficiency, reliability and the environmental impact of power supply systems are issues of global concern:

- Fossil fuel power plants operate at ~35% efficiency
- 5% of generated power is lost during transmission
- Power outages and interruptions result in \$150 billion in losses annually [1]
- Fossil fuel plants in the US generate 40% of the national carbon emissions linked with global warming [2]

A Perfect Power Demonstration System

- *Abiodun Iwayemi, Peizhong Yi, Peng Liu, Chi Zhou*

Introduction – The Solution

The smart grid concept specifies the addition of intelligence and two-way digital communication to the power grid to significantly improve system efficiency, reliability and security:

Smart Grid Features:

- Smart metering
- Rapid outage detection
- Real-time pricing feedback
- Demand response facilitation
- Greater incorporation of renewable energy sources

A Perfect Power Demonstration System

- *Abiodun Iwayemi, Peizhong Yi, Peng Liu, Chi Zhou*

The IIT Perfect Power Project

A Perfect Power System is being pioneered by the Illinois Institute of Technology. A Perfect Power System is a micro-smart grid, which extends the smart grid with the following features :

- Redundant power links
- Bidirectional power flows
- Onsite/local power generation

The Perfect Power system is based on a hierarchical model whereby efficient energy management is performed at the building level then aggregated over a large area

A Perfect Power Demonstration System

- *Abiodun Iwayemi, Peizhong Yi, Peng Liu , Chi Zhou*

The IIT Perfect Power Project

Smart Grid principles present in the IIT Perfect Power Project :

- Demand Response
- Onsite Power generation
- Smart metering
- Redundant power links
- Large and small scale system monitoring and control using Zigbee wireless networking

A Perfect Power Demonstration System

- *Abiodun Iwayemi, Peizhong Yi, Peng Liu, Chi Zhou*

The IIT Perfect Power Project

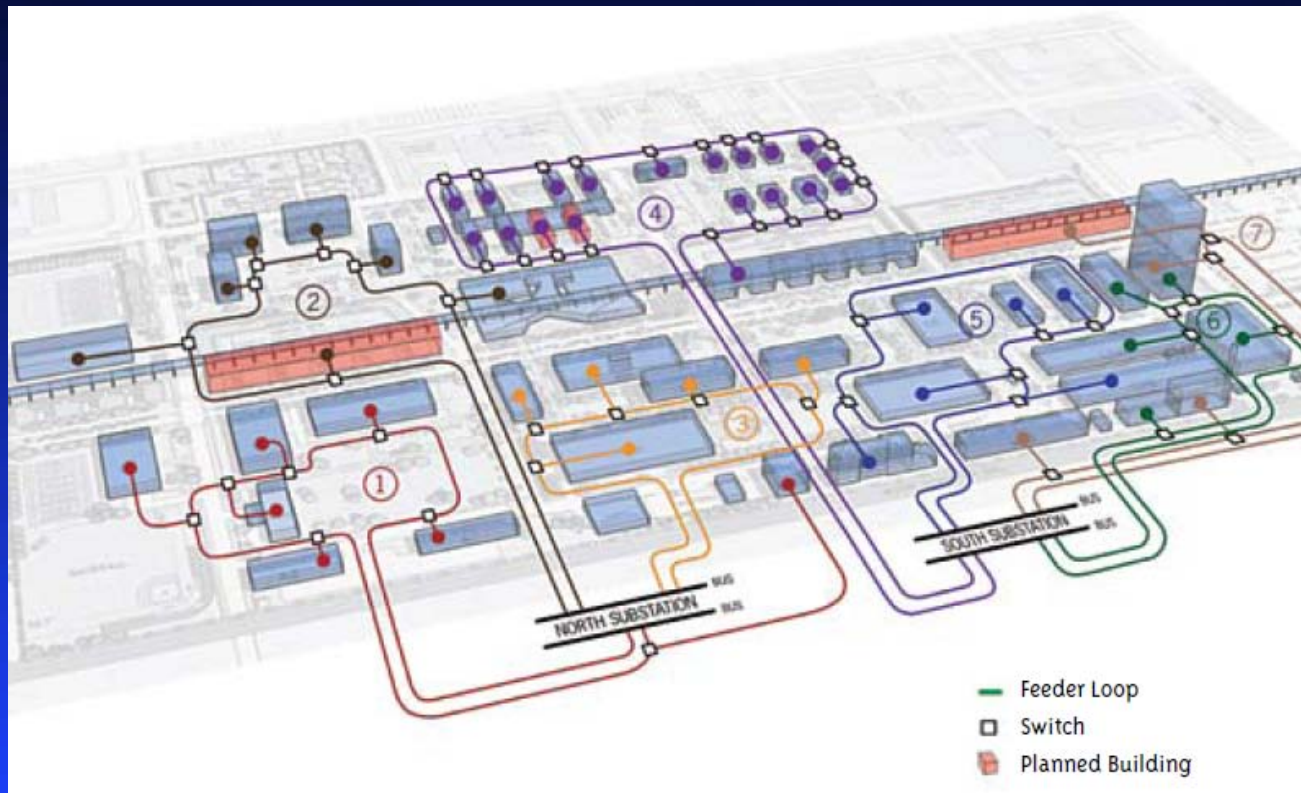

High reliability distribution system

A Perfect Power Demonstration System

- *Abiodun Iwayemi, Peizhong Yi, Peng Liu, Chi Zhou*

The IIT Perfect Power Project

Perfect Power System Goals:

- Design a system that can be replicated to any microgrid
- Demonstrate its technological viability
- Have the capability to reduce the peak on-demand by 50%
- Demonstrate the economic value of Perfect Power
- Satisfaction of energy demand in terms of quality and quantity 100% of the time [3]
- Granular real-time system health monitoring
- Rapid outage detection
- Greater incorporation of renewable energy sources

A Perfect Power Demonstration System

- *Abiodun Iwayemi, Peizhong Yi, Peng Liu, Chi Zhou*

COMMUNICATION WITHIN THE PERFECT POWER PROJECT

A Perfect Power Demonstration System

- *Abiodun Iwayemi, Peizhong Yi, Peng Liu, Chi Zhou*

The Zigbee Standard

- The Zigbee standard is a wireless short range, low power, low cost and complexity networking scheme based on the IEEE 802.15.4 standard.
- Zigbee was selected as the wireless networking scheme to be used to interconnect sensors, actuators and building Controllers in the IIT Perfect Power System due to its cost and flexibility



A Perfect Power Demonstration System

- *Abiodun Iwayemi, Peizhong Yi, Peng Liu, Chi Zhou*

The Zigbee Standard

Zigbee Features:

- Low-data rates (max of 250kbps in 2.4 GHz spectrum)
- Self-organizing mesh, star or cluster topologies
- Self-healing links and routing capabilities
- Low-data rates (max of 250kbps in 2.4 GHz spectrum)
- Long battery life, up to 5 years on AA batteries

A Perfect Power Demonstration System

- *Abiodun Iwayemi, Peizhong Yi, Peng Liu, Chi Zhou*

Zigbee Network Components

Each Zigbee network is made up of 2 device Categories:

1. Full-function Devices (FFD's)
2. Reduced Function Devices (RFD's)

Full Function Devices	Reduced Function Devices
<ul style="list-style-type: none">• Network establishment• Network management• Routing	<ul style="list-style-type: none">• Reduced feature set and can only communicate with routers.• Peer to peer communication not possible

A Perfect Power Demonstration System

- *Abiodun Iwayemi, Peizhong Yi, Peng Liu, Chi Zhou*

Zigbee Network Components

Zigbee devices can act in 3 roles:

- Zigbee Coordinator (FFD)
- Zigbee Router (FFD)
- Zigbee End Device (RFD)

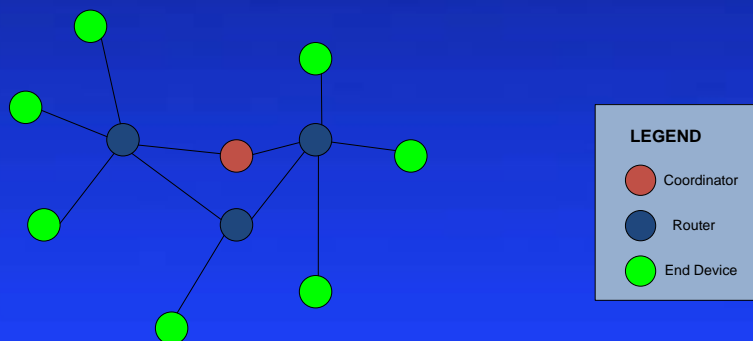

Cluster Tree Network Architecture

A Perfect Power Demonstration System

- *Abiodun Iwayemi, Peizhong Yi, Peng Liu, Chi Zhou*

The Perfect Power Demonstration System

The Perfect Power Demonstration System Test bed is a proof of concept for:

- The Perfect Power system controller
- Building energy management system
- Campus wide wireless networking using Zigbee for Smart grid applications

A Perfect Power Demonstration System

- *Abiodun Iwayemi, Peizhong Yi, Peng Liu, Chi Zhou*

The Perfect Power Test Bed

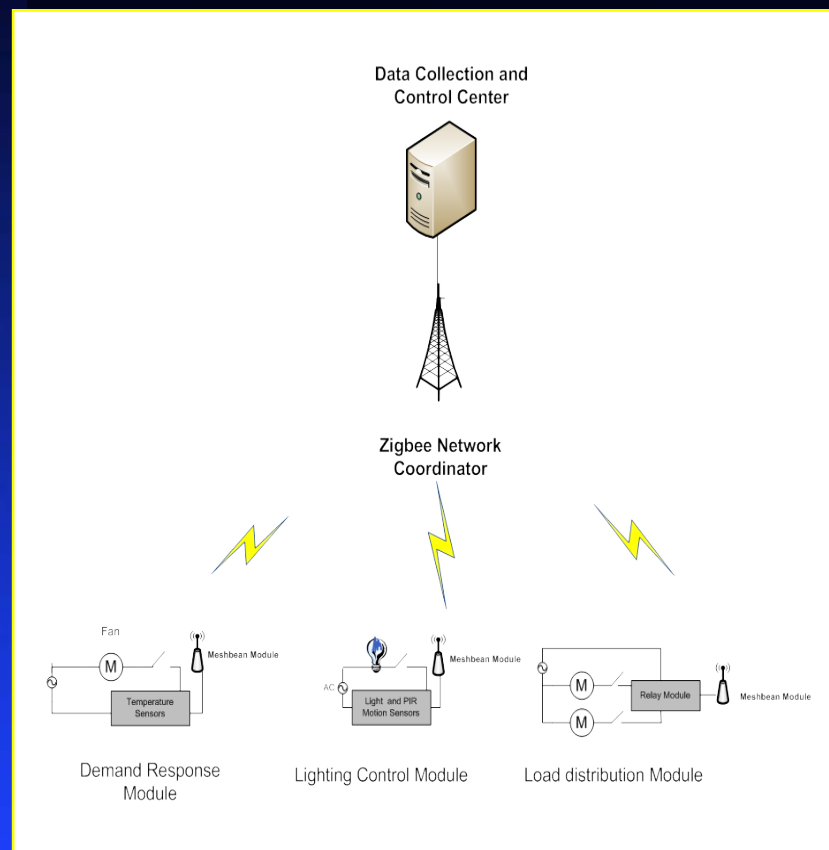

Network Architecture

A Perfect Power Demonstration System

- *Abiodun Iwayemi, Peizhong Yi, Peng Liu, Chi Zhou*

The Perfect Power Test Bed

The Test bed consists of the following elements:

- A Data Collection and Control Center (DCCC)
- 4 Meshnetics Meshbean2 Zigbee motes
- 1 Lighting Actuation module
- 1 Power source switching module
- 1 Load actuation module
- 3 Loads



A Perfect Power Demonstration System

- *Abiodun Iwayemi, Peizhong Yi, Peng Liu, Chi Zhou*

The Perfect Power Test Bed

The Data Collection and Control Center (DCCC):

- Serves as the system controller
- Displays received sensor data
- Manual control of remote Zigbee Modules
- Control of externally connected loads on the basis of user determined price thresholds, time of day and sensor readings
- Lighting control based on room occupancy and other variables.

A Perfect Power Demonstration System

- *Abiodun Iwayemi, Peizhong Yi, Peng Liu, Chi Zhou*

The Perfect Power Test Bed

The Data Collection and Control Center (DCCC):

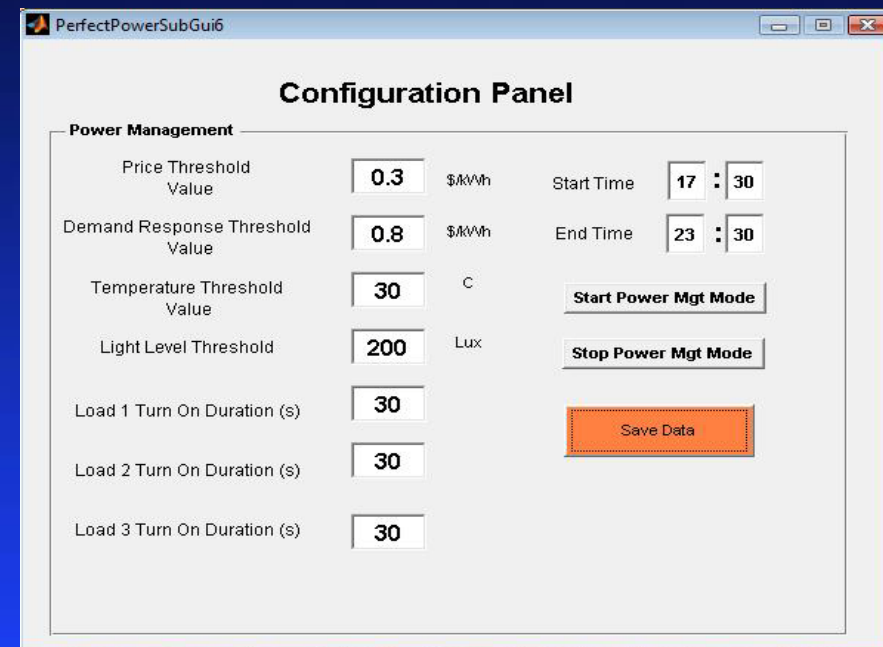
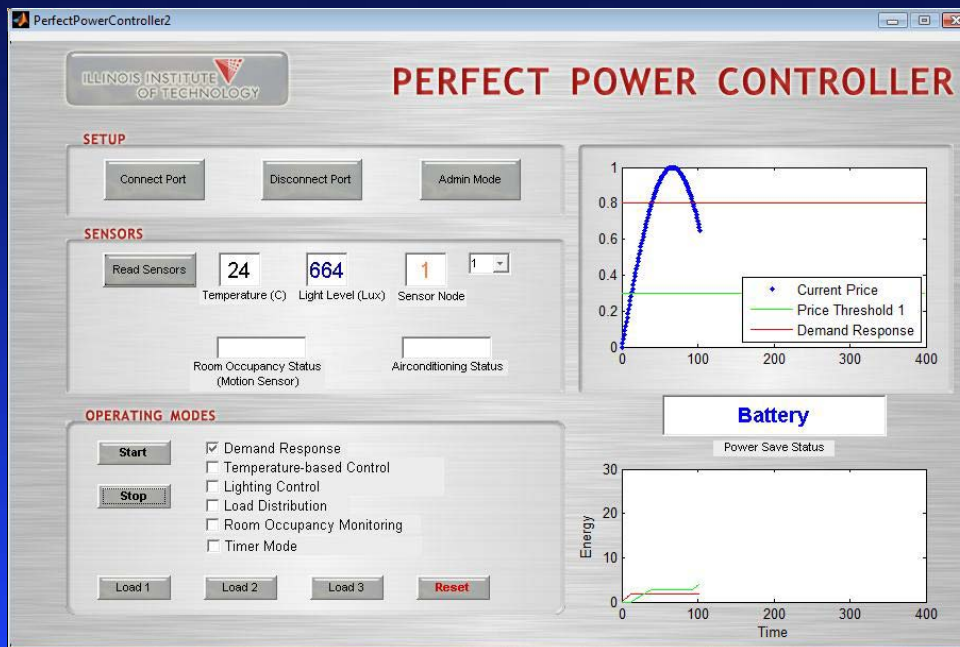

DCCC Screenshots

A Perfect Power Demonstration System

- *Abiodun Iwayemi, Peizhong Yi, Peng Liu, Chi Zhou*

The Perfect Power Test Bed

Meshnetics Meshbean Zigbee Motes:

- 128k Flash memory
- 8K RAM
- Current consumption: 19mA/18mA (RX/TX), 6 μ A (Sleep)

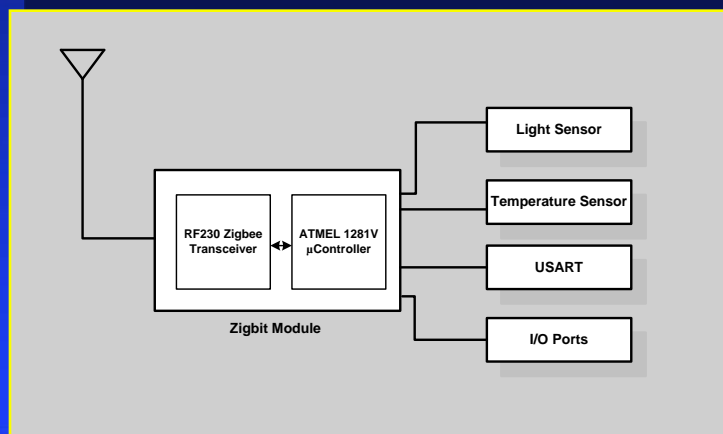

Meshbean2 block diagram

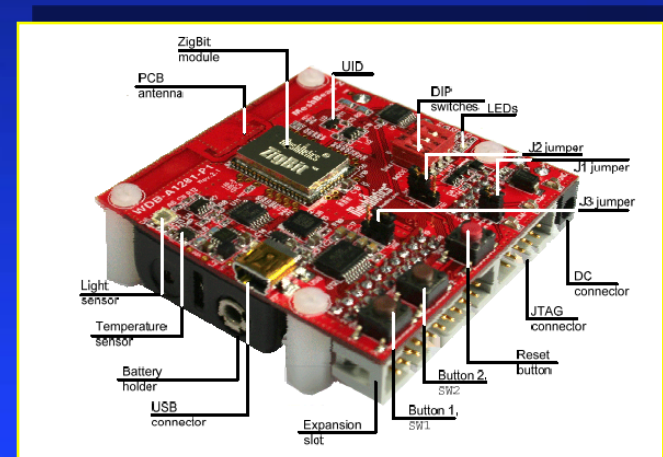

Meshbean2 Zigbee Mote

A Perfect Power Demonstration System

- *Abiodun Iwayemi, Peizhong Yi, Peng Liu, Chi Zhou*

Demonstration Modes

Three different demonstration modes were developed:

1. Demand Response
2. Load scheduling
3. Lighting Control
4. Ambient Temperature Sensing and Control

A Perfect Power Demonstration System

- *Abiodun Iwayemi, Peizhong Yi, Peng Liu, Chi Zhou*

Demonstration Modes

Demand response and load scheduling modules were developed enable demand response and the scheduling of load actuation based on current power pricing. These modules also enabled loads to be switched between utility and on-site generation power sources

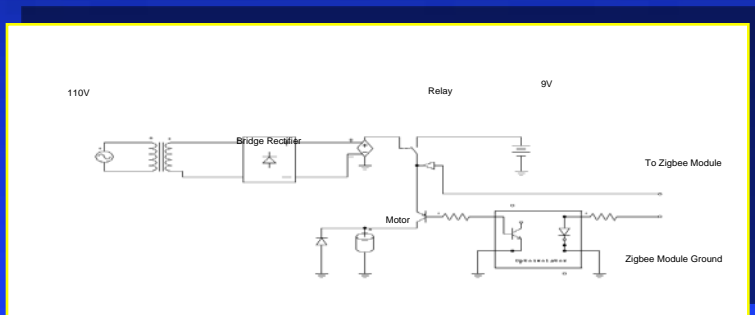

Demand Response actuation circuit

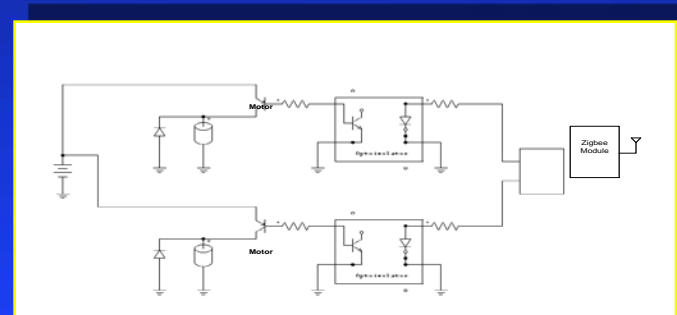

Load Distribution circuit

A Perfect Power Demonstration System

- *Abiodun Iwayemi, Peizhong Yi, Peng Liu, Chi Zhou*

Demonstration Modes

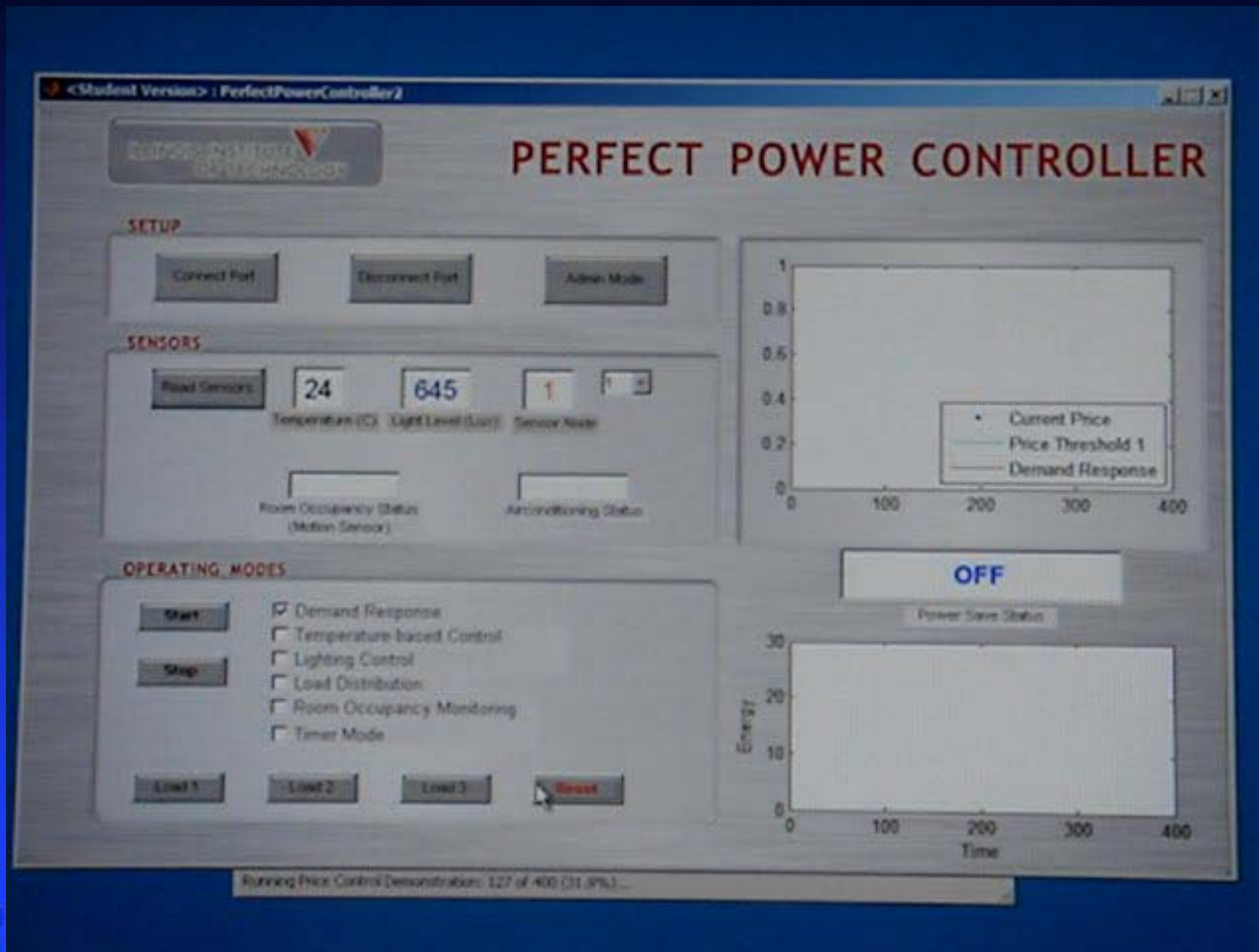

A Perfect Power Demonstration System

- *Abiodun Iwayemi, Peizhong Yi, Peng Liu, Chi Zhou*

Demonstration Modes – Lighting Control

We developed a room-occupancy and lighting actuation module to enable light sensing and lamp actuation using the Perfect Power demonstration platform.

Decision Inputs:

- Room occupancy (via PIR sensor)
- Lighting level
- Time of day



Occupancy Sensing and Lighting Actuation Module

A Perfect Power Demonstration System

- *Abiodun Iwayemi, Peizhong Yi, Peng Liu, Chi Zhou*

Demonstration Modes – Lighting Control

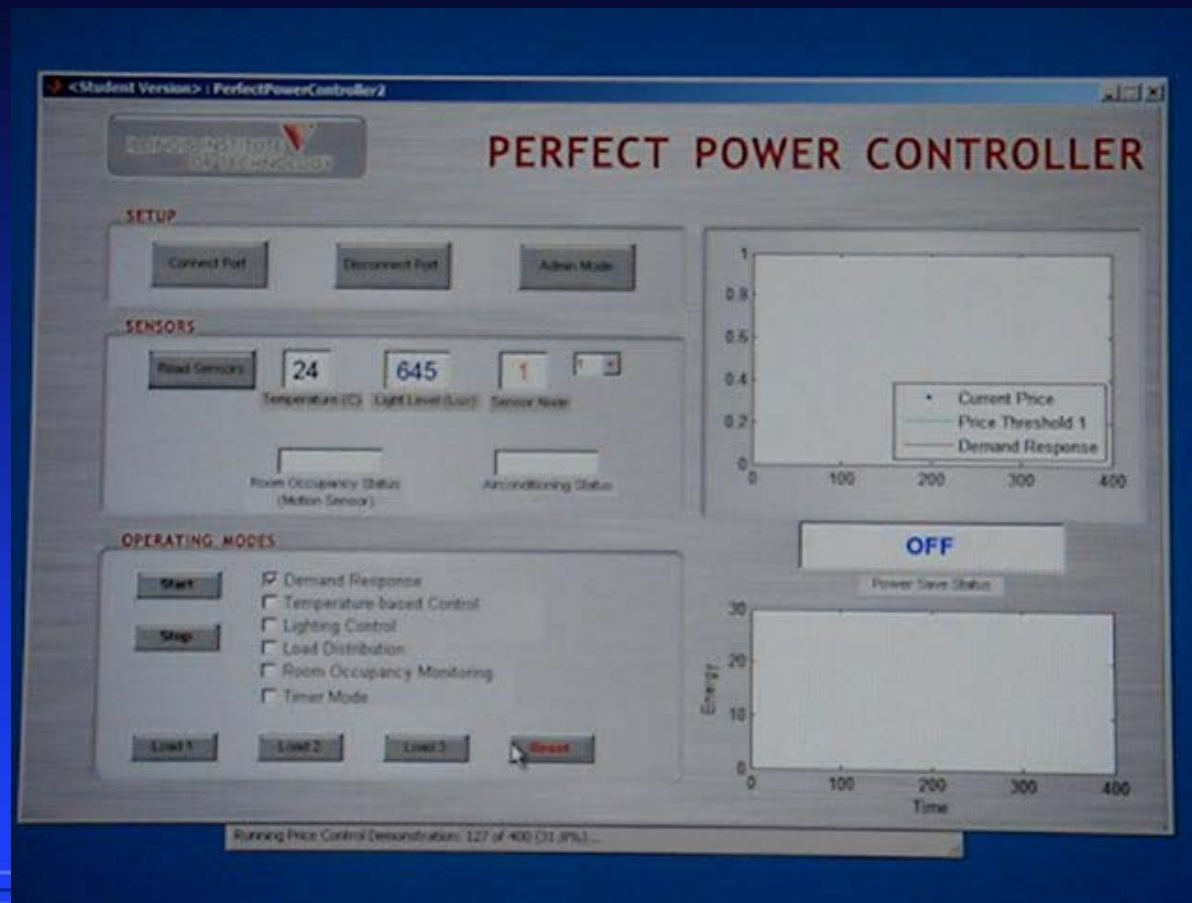

A Perfect Power Demonstration System

- *Abiodun Iwayemi, Peizhong Yi, Peng Liu, Chi Zhou*

Demonstration Modes – Ambient Temperature Control

- Heating, Ventilation and Air-conditioning (HVAC) is the second significant power consumer within buildings.
- Granular sensing of temperature throughout the building enables more efficient environmental control and a more comfortable work environment for building occupants.

A Perfect Power Demonstration System

- *Abiodun Iwayemi, Peizhong Yi, Peng Liu, Chi Zhou*

Demonstration Modes – Ambient Temperature Control

Ambient temperature monitoring and control was achieved by means of the Demand response module and the on-board LM73CIMK temperature sensor on the Zigbee mote.

- Periodic temperature measurements were taken from remote Zigbee devices
- Load actuation (Cooling Fan) performed on the basis of the user configured temperature threshold values.
- The readings from different points within a building can be combined to obtain a detailed picture of building temperature distributions, which can then be used for highly-accurate and automated building environment control

A Perfect Power Demonstration System

- *Abiodun Iwayemi, Peizhong Yi, Peng Liu, Chi Zhou*

Conclusion

We developed a MATLAB-based Perfect Power Controller System and demonstrated how Zigbee-enabled sensors and actuators can be leveraged to enhance building energy management, and permit granular control of electrical and HVAC systems for smart grid applications.

A Perfect Power Demonstration System

- *Abiodun Iwayemi, Peizhong Yi, Peng Liu, Chi Zhou*

Future Work

- Deployment of a Zigbee sensor and control network throughout the Electrical and Computer Engineer building at IIT, to monitor HVAC systems, measure ambient lighting levels and temperature, control designated lighting systems within the building.
- Development of a Smart Grid test center where manufacturers can connect their products to the IIT Smart Grid and test their devices performance within a live smart grid architecture.

A Perfect Power Demonstration System

- *Abiodun Iwayemi, Peizhong Yi, Peng Liu, Chi Zhou*

References

- [1] United States Department of Energy Whitepaper, "The Smart Grid: An Introduction," 2008.
- [2] M. Wenzler, *Cleaning up Air Pollution from America's Power Plants: The Facts*, National Environment Trust, 2002.
- [3] "The Galvin Path to Perfect Power - A Technical Assessment: Report on the Galvin Electricity Initiative, Phase II, Tasks 1 & 2," *Galvin Electricity Initiative*,
http://www.galvinpower.org/files/Perfect_Power_Technical_Assessment.pdf, 2007.
- [4] F. Rubinstein, M. Siminovitch, and R. Verderber, "Fifty percent energy savings with automatic lighting controls," *Industry Applications, IEEE Transactions on*, vol. 29, 1993, pp. 768-773.

A Perfect Power Demonstration System

- *Abiodun Iwayemi, Peizhong Yi, Peng Liu , Chi Zhou*

Thank you